

Low noise triple fixed displacement vane pumps SQP series

B
3-1

Fixed Displacement Vane Pumps

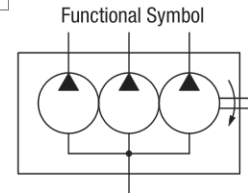
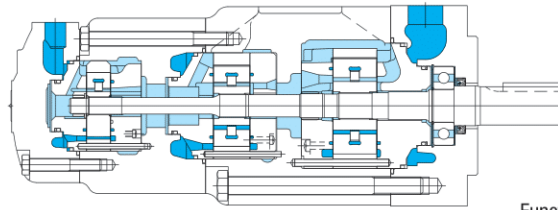
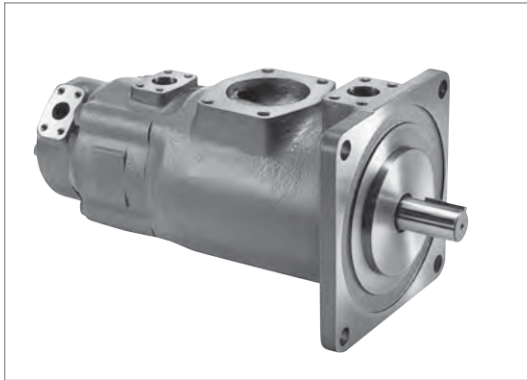

Model Code

(F3)-SQP432-60-38-15-86CCC(2)-(LH)-18

1 2 3 4 5 6 7 8 9 10 11 12

1 Hydraulic fluid

Omit: mineral oil based fluid
F3: Phosphate ester fluid
F11: Water glycol fluid

2 Low noise triple fixed displacement vane pumps

SQP211 Series
SQP311, 321 Series
SQP421, 431, 432 Series

3 Shaft end pump displacement

Series	Displacement Code
SQP2**	10, 12, 14, 15, 17, 19, 21
SQP3**	17, 21, 25, 30, 32, 35, 38
SQP4**	30, 35, 38, 42, 50, 60

4 Middle pump displacement

Series	Displacement Code
SQP*1*	2, 3, 4, 5, 6, 7, 8, 9, 11, 12, 14
SQP*2*	10, 12, 14, 15, 17, 19, 21
SQP*3*	17, 21, 25, 30, 32, 35, 38

5 Cover end pump displacement

Series	Displacement Code
SQP**1	2, 3, 4, 5, 6, 7, 8, (9), (11), (12), (14)
SQP**2	10, 12, 14, 15, 17, 19, 21

Note: Applicable series with displacements indicated by () are limited. See page B3-2.

6 Shaft end configuration

86: parallel sq. key

7 Shaft end delivery port position (viewed from cover end)

A: opposite suction port
B: 90° CCW from suction port
C: inline with suction port
D: 90° CW from suction port

8 Middle pump delivery port position (viewed from cover end)

SQP211, 311, 321, 421
A: 135° CCW from suction port
B: 45° CCW from suction port
C: 45° CW from suction port
D: 135° CW from suction port
SQP431, 432
A: opposite suction port
B: 90° CCW from suction port
C: inline with suction port
D: 90° CW from suction port

9 Cover end delivery port position (viewed from cover end)

SQP211, 311, 431, 432
A: 135° CCW from suction port
B: 45° CCW from suction port
C: 45° CW from suction port
D: 135° CW from suction port
SQP321, 421
A: opposite suction port
B: 90° CCW from suction port
C: inline with suction port
D: 90° CW from suction port

10 Pump mounting

Omit: flange mounting
2*: foot mounting
Shaft end delivery port position relative to foot mounting surface (see schematics on B2-1)

Foot Mounting Code	Position of the Shaft End Delivery Port as Viewed from the Shaft End
2	Up (12 o'clock)
23	Right (3 o'clock)
26	Down (6 o'clock)
29	Left (9 o'clock)

11 Rotation (viewed from shaft end)

Omit: CW
LH: CCW

12 Design no.

Model Code

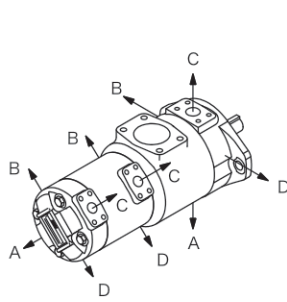

• SQP 211 Series
• SQP 311 Series

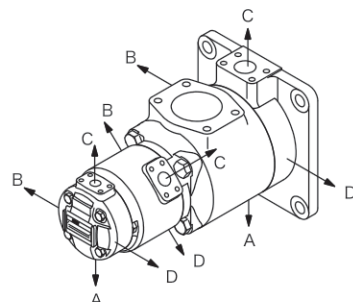

• SQP 321 Series
• SQP 421 Series

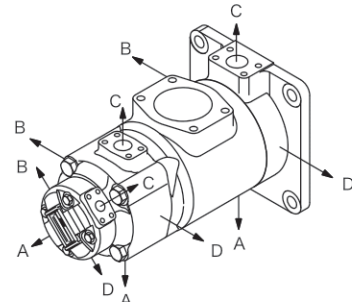

• SQP 431 Series
• SQP 432 Series

B
3-2

Fixed Displacement Vane Pumps

Specifications

Model Code	Shaft End Pump			Middle Pump			Cover End Pump						Min. Speed min ⁻¹
	Displacement Code	Del. at 1000 min ⁻¹ 0.7 Mpa	Max. Working Pressure MPa	Displacement Code	Del. at 1000 min ⁻¹ 0.7 Mpa	Max. Working Pressure MPa	Displacement Code	Del. at 1000 min ⁻¹ 0.7 Mpa	Max. Working Pressure MPa	Max. Speed min ⁻¹			
										Mineral oil based fluid	Water glycol based fluid	Phosphate ester fluid	
SQP211	10	32.5	17.5	2	7.5	14	2	7.5	14	1800	1200	1200	600
	12	38.3		3	10.2		3	10.2					
	14	43.3		4	12.8		4	12.8					
	15	46.7		5	16.7		5	16.7					
	17	52.5		6	19.2		6	19.2					
	19	59.2		7	22.9		7	22.9					
	21	65.0		8	26.2		8	26.2					
SQP311	17	53.3	17.5	8	26.2	16	6	19.2	17.5	1500	1000	1000	600
	21	66.7		9	28.3		7	22.9					
	25	79.2		11	35.0		8	26.2					
	30	95.0		12	37.9		14	44.2					
	32	100.0		14	44.2		14	44.2					
	35	109.0		10	32.5		2	7.5					
	38	118.0		12	38.3		3	10.2					
SQP321	17	53.3	17.5	10	32.5	17.5	2	7.5	14	1800	1200	1200	600
	21	66.7		12	38.3		3	10.2					
	25	79.2		14	43.3		4	12.8					
	30	95.0		15	46.7		5	16.7					
	32	100.0		17	52.5		6	19.2					
	35	109.0		19	59.2		7	22.9					
	38	118.0		21	65.0		8	26.2					
SQP421	30	96.0	17.5	17	52.5	17.5	7	22.9	17.5	1500	1000	1000	600
	35	109.0		19	59.2		8	26.2					
	38	128.0		21	65.0		9	28.3					
	42	134.0		10	32.5		11	35.0					
	50	156.0		17	53.3		2	7.5					
	60	189.0		21	66.7		3	10.2					
	SQP431	30		96.0	17.5		25	79.2		17.5			
35		109.0	30	95.0		5	16.7						
38		128.0	32	100.0		6	19.2						
42		134.0	35	109.0		7	22.9						
50		156.0	38	118.0		8	26.2						
60		189.0	38	118.0		9	28.3						
SQP432		30	96.0	17.5		17	53.3	17.5	10		32.5	17.5	1800
	35	109.0	21		66.7	12	38.3						
	38	128.0	25		79.2	14	43.3						
	42	134.0	30		95.0	15	46.7						
	50	156.0	32		100.0	17	52.5						
	60	189.0	35		109.0	19	59.2						
			38		118.0	21	65.0						

Note: • Max. working pressure is 14 MPa for phosphate-ester fluid.
• Max. speed may vary depending on displacement of cover side pump.

Weight, Delivery, Shaft Input Power

Model Code	Delivery, shaft input			Weight kg	
	Shaft End Pump	Middle Pump	Cover End Pump	Flange Mounting	Foot Mounting
SQP211	Same as SQP2 Series	Same as SQP1 Series	Same as SQP1 Series	40.0	49.5
SQP311	Same as SQP3 Series			60.0	69.5
SQP321	Same as SQP3 Series	Same as SQP2 Series	Same as SQP1 Series	62.0	71.5
SQP421	Same as SQP4 Series			88.0	113.0
SQP431	Same as SQP4 Series	Same as SQP3 Series	Same as SQP1 Series	97.0	122.0
SQP432	Same as SQP4 Series			104.0	129.0

*SQP1 ~ SQP4 delivery, shaft input - see page B1-4, 1-5.

Notes on Operation

- See page B0-4 for Notes on Using Vane Pumps.

Shaft Input (Shaft Torque) Limitation

Shaft torque limitations of triple pumps are shown in the table. Please ensure that the total of the maximum load of the three pumps do not exceed the torque limit shown in the table. Please calculate shaft torque from the operating speed and shaft input.

N : operating speed (min^{-1})

L : shaft input sum (kW)

Shaft torque: $T = (60 \times 1000 / 2\pi N) \times L = (9554/N) \times L$ (N·m)

(Example) SQP432-60-38-14, operating speed 1200 min^{-1} , first pump 14 MPa, second pump 17.5 MPa under max. load,
First pump shaft input: from table on page B1-5, SQP4-60 shaft input is 57.1 kW

Second pump shaft input: from table on page B1-5, SQP3-38 shaft input is 36.2 kW

Third pump shaft input: from table on page B1-4, SQP2-14 shaft input is 18.4 kW

Shaft input sum: $L = 57.1 + 36.2 + 18.4 = 111.7$ (kW)

Shaft input sum substituted for torque in the table,

Shaft input torque: $T = 9554 \times 111.7 / 1200 = 889.3$ (N·m)

Thus, the shaft torque is below the limitation of 950 N·m for SQP432

Please confirm shaft torque using this procedure.

Model Code	Shaft Torque Limitation N·m
SQP211	360
SQP311	610
SQP321	610
SQP421	950
SQP431	950
SQP432	950

Piping Flanges (Compliant to SAE J 518c Standard Pressure)

- Flanges sold separately.
- Refer to table below to order flanges (with hex socket bolts, spring washers, and O-rings).
- See page R7-1 for dimensions, etc.

Pump Model	Type	Flange Type							
		Suction Port			Delivery Port				
		Size		Size	No. 1 Port (Shaft End)	Size	No. 2 Port (Middle)	Size	No. 3 Port (Cover End)
SQP211	Threaded	2-1/2	FL1-20-20P-10-JA-S4-J	1	FL1-8-08P-10-JA-S4-J	3/4	FL1-6-06P-10-JA-S4-J	3/4	FL1-6-06P-10-JA-S4-J
	Welded		FL1-20-20W-10-JA		FL1-8-08W-10-JA		FL1-6-06W-10-JA		FL1-6-06W-10-JA
SQP311	Threaded	3	FL1-24-24P-10-JA-S4-J	1-1/4	FL1-10-10P-10-JA-S4-J	3/4	FL1-6-06P-10-JA-S4-J	3/4	FL1-6-06P-10-JA-S4-J
	Welded		FL1-24-24W-10-JA		FL1-10-10W-10-JA		FL1-6-06W-10-JA		FL1-6-06W-10-JA
SQP321	Threaded	3	FL1-24-24P-10-JA-S4-J	1-1/4	FL1-10-10P-10-JA-S4-J	1	FL1-8-08P-10-JA-S4-J	3/4	FL1-6-06P-10-JA-S4-J
	Welded		FL1-24-24W-10-JA		FL1-10-10W-10-JA		FL1-8-08W-10-JA		FL1-6-06W-10-JA
SQP421	Threaded	3-1/2	_____	1-1/2	FL1-12-12P-10-JA-S4-J	1	FL1-8-08P-10-JA-S4-J	3/4	FL1-6-06P-10-JA-S4-J
	Welded		FL1-28-28W-10-JA		FL1-12-12W-10-JA		FL1-8-08W-10-JA		FL1-6-06W-10-JA
SQP431	Threaded	4	_____	1-1/2	FL1-12-12P-10-JA-S4-J	1-1/4	FL1-10-10P-10-JA-S4-J	3/4	FL1-6-06P-10-JA-S4-J
	Welded		FL1-32-32W-10-JA		FL1-12-12W-10-JA		FL1-10-10W-10-JA		FL1-6-06W-10-JA
SQP432	Threaded	4	_____	1-1/2	FL1-12-12P-10-JA-S4-J	1-1/4	FL1-10-10P-10-JA-S4-J	1	FL1-8-08P-10-JA-S4-J
	Welded		FL1-32-32W-10-JA		FL1-12-12W-10-JA		FL1-10-10W-10-JA		FL1-8-08W-10-JA

Dimensions

SQP211 (Flange mounting)

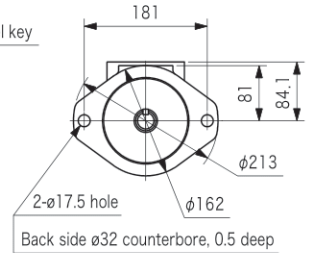
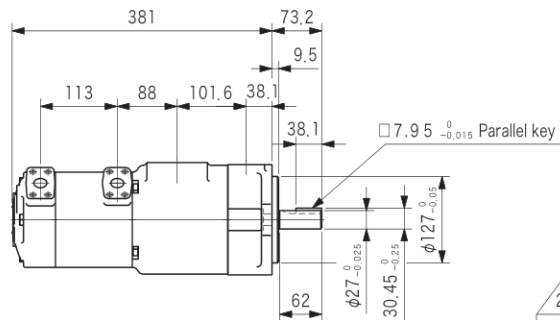
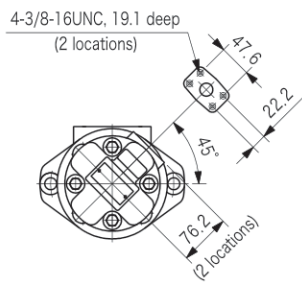
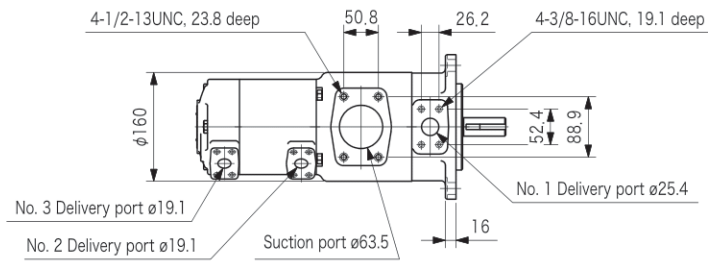

(Foot mounting)

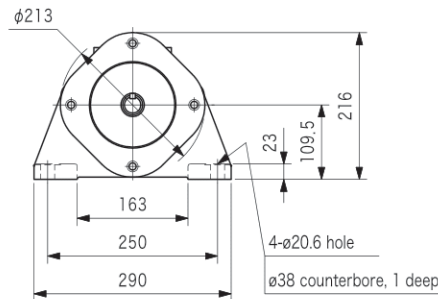
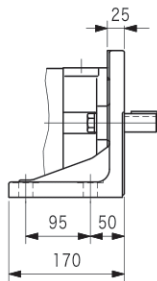

SQP311 (Flange mounting)

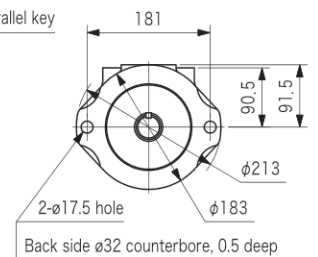
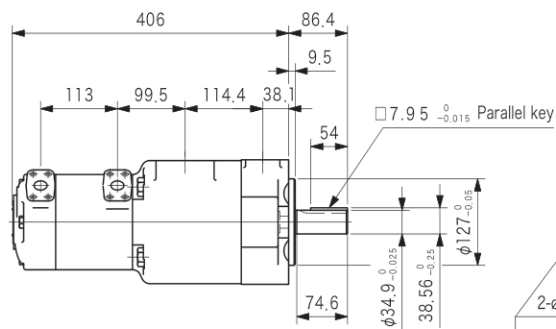
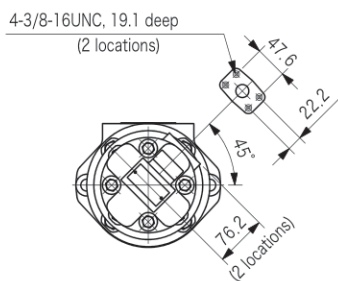
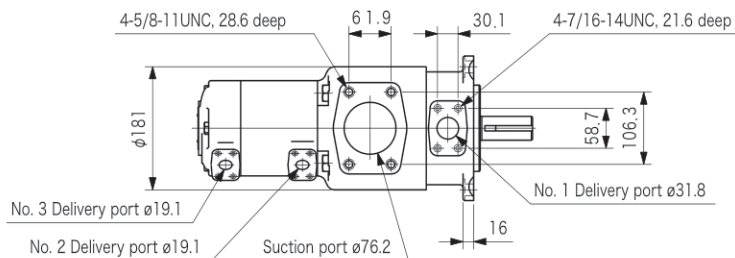

(Foot mounting)

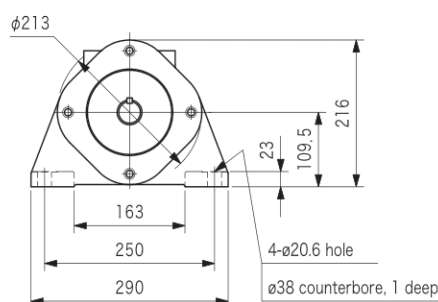
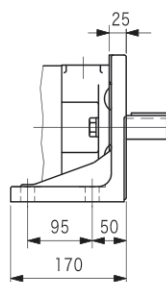

Dimensions

B
3-5

Fixed Displacement Vane Pumps

SQP321 (Flange mounting)

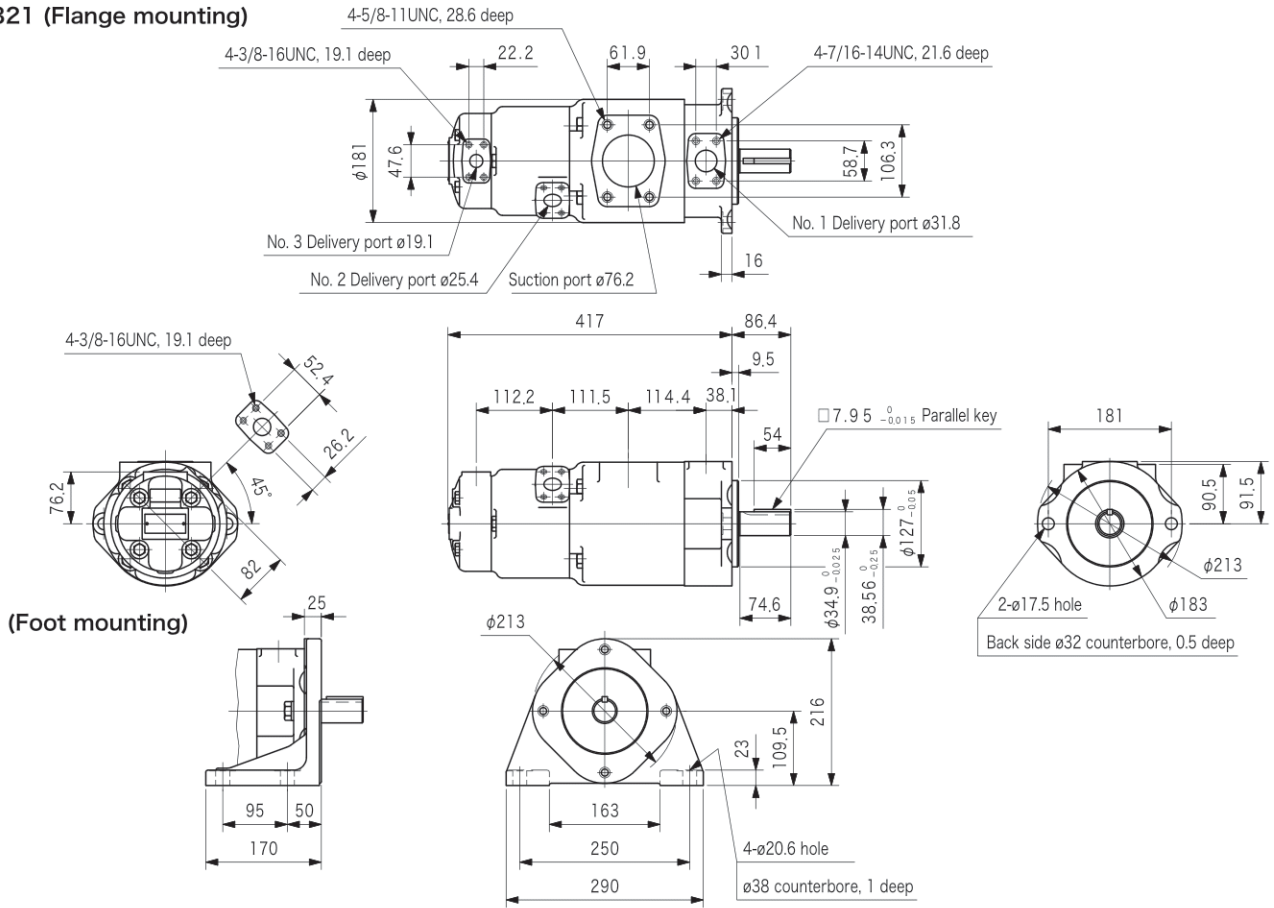

SQP421 (Flange mounting)

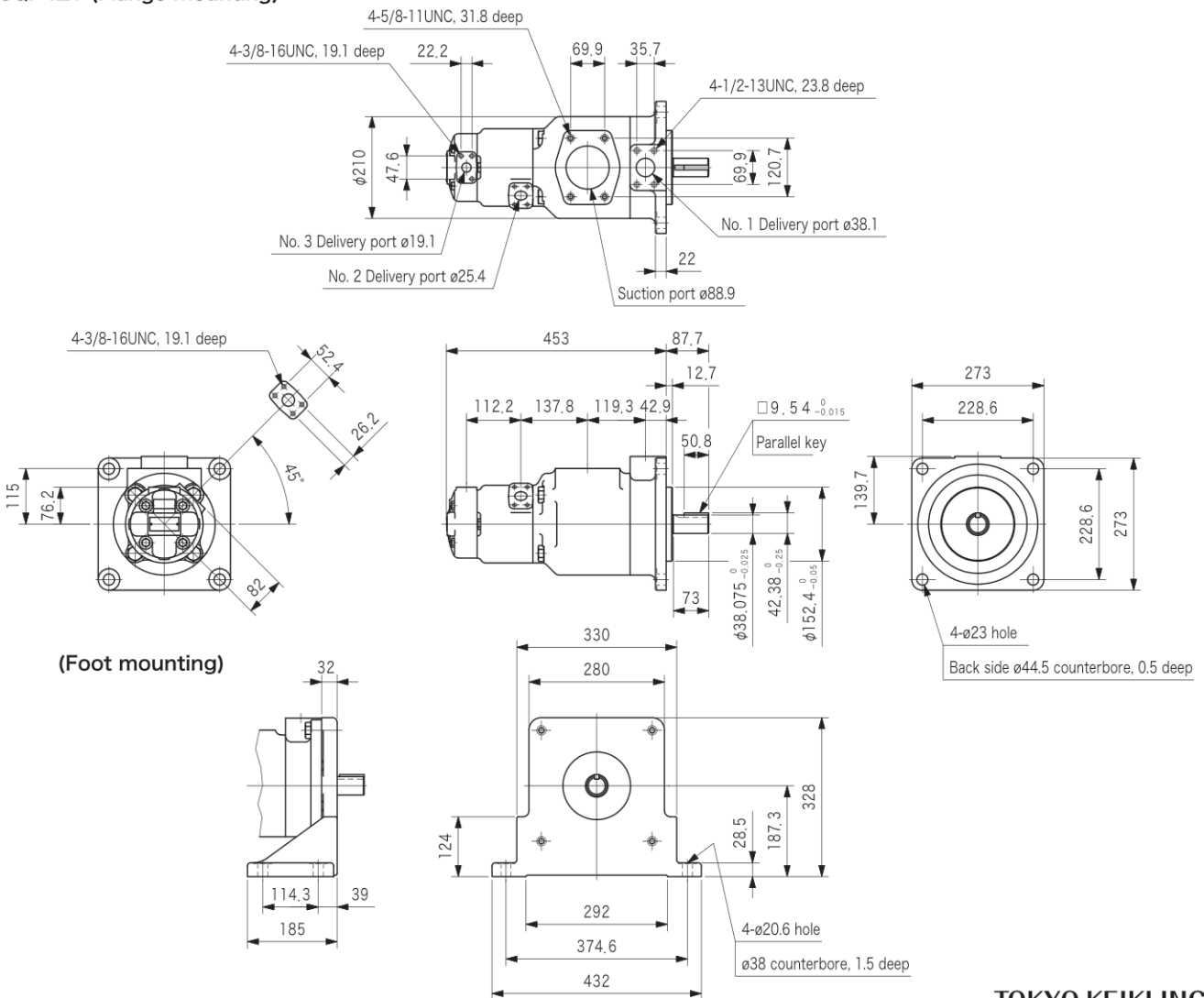

Dimensions

SQP431 (Flange mounting)

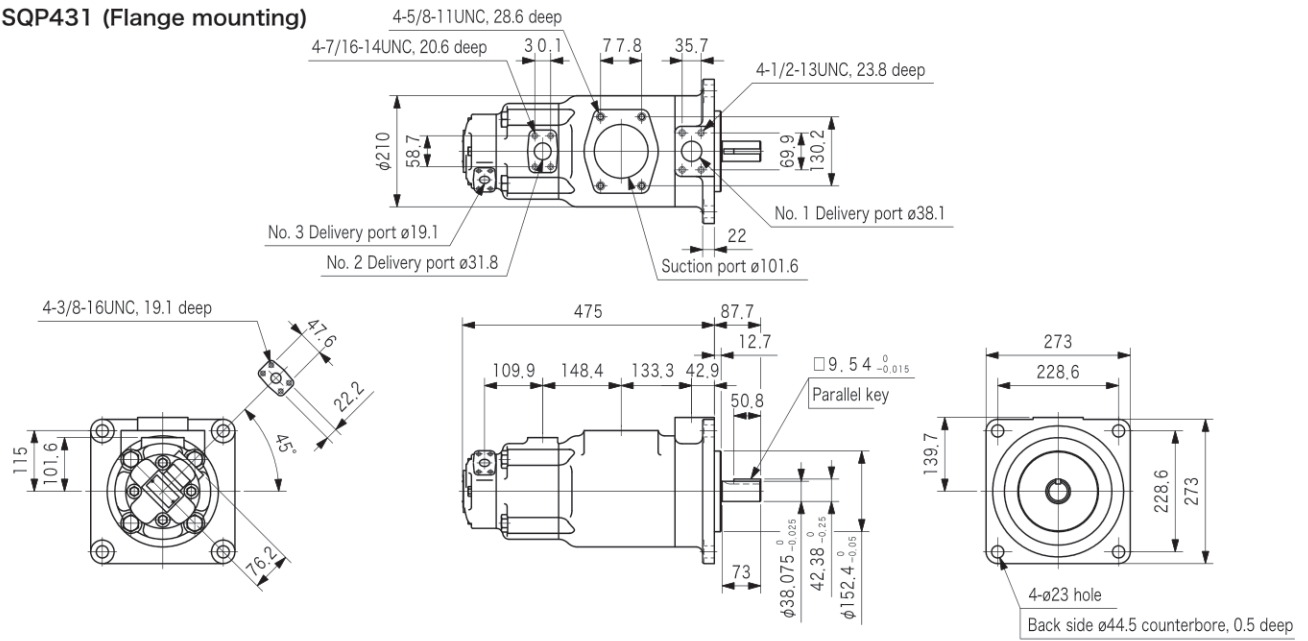

(Foot mounting)

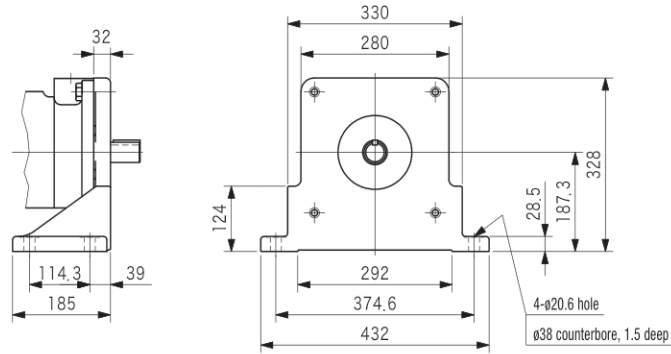

SQP432 (Flange mounting)

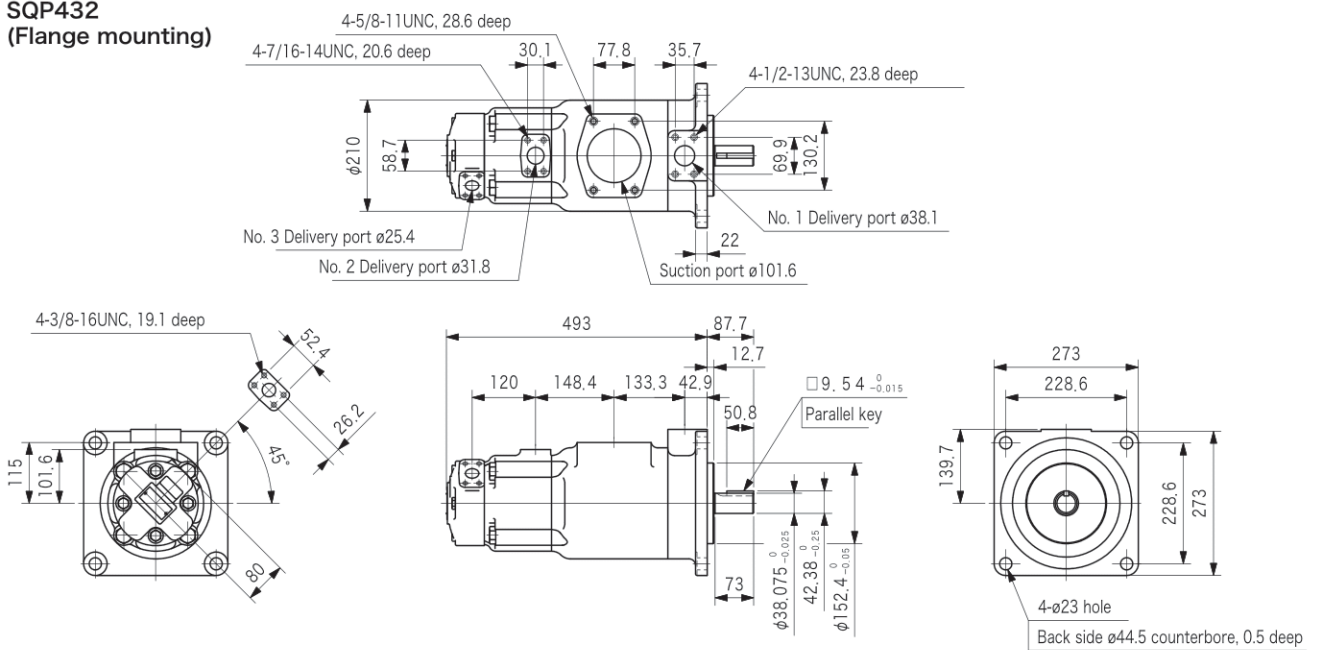

(Foot mounting)

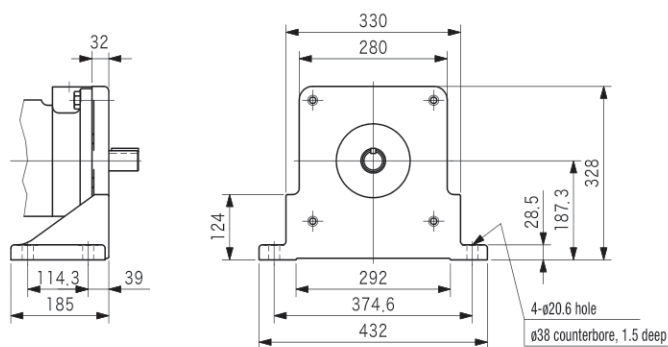

SQP211 Series
SQP311 Series

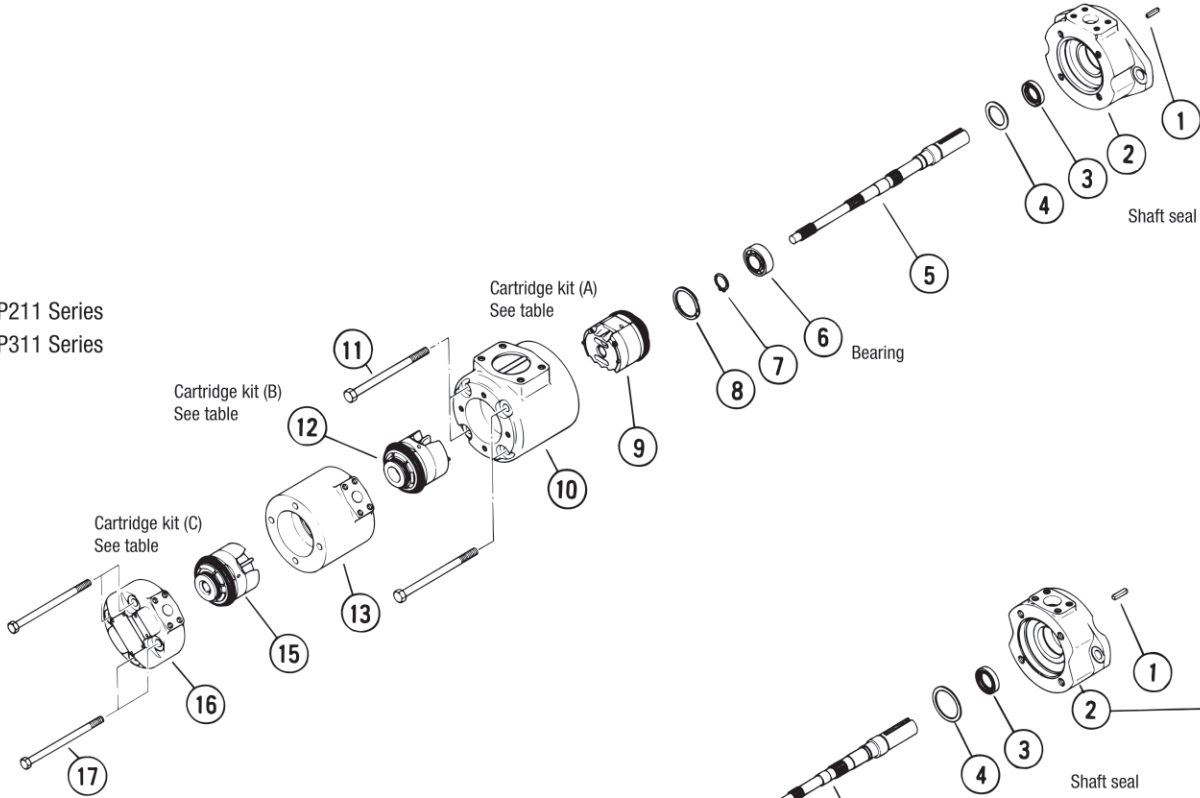

SQP321 Series
SQP421 Series

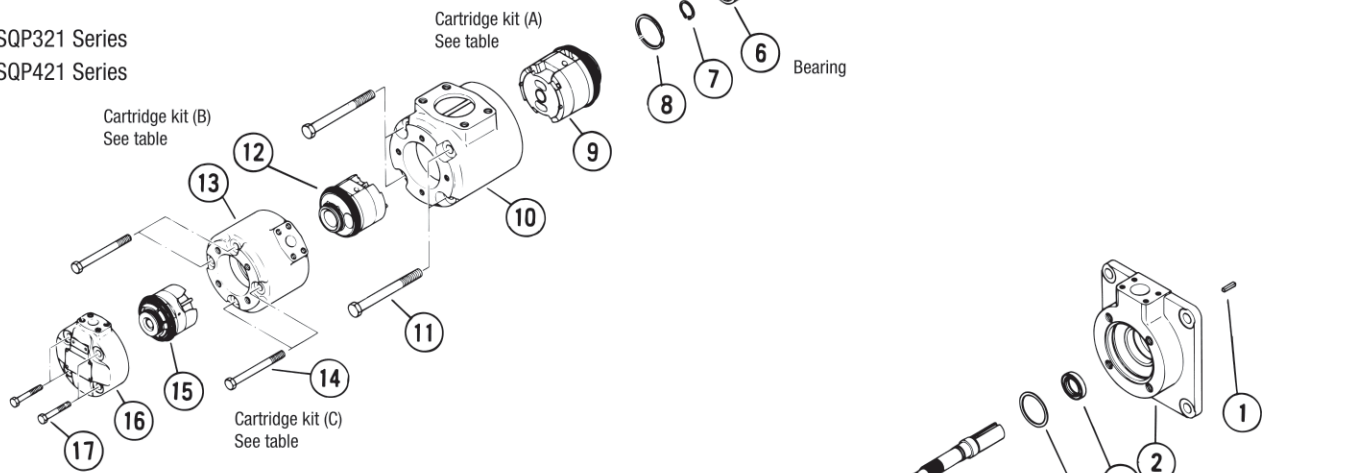

SQP431 Series
SQP432 Series

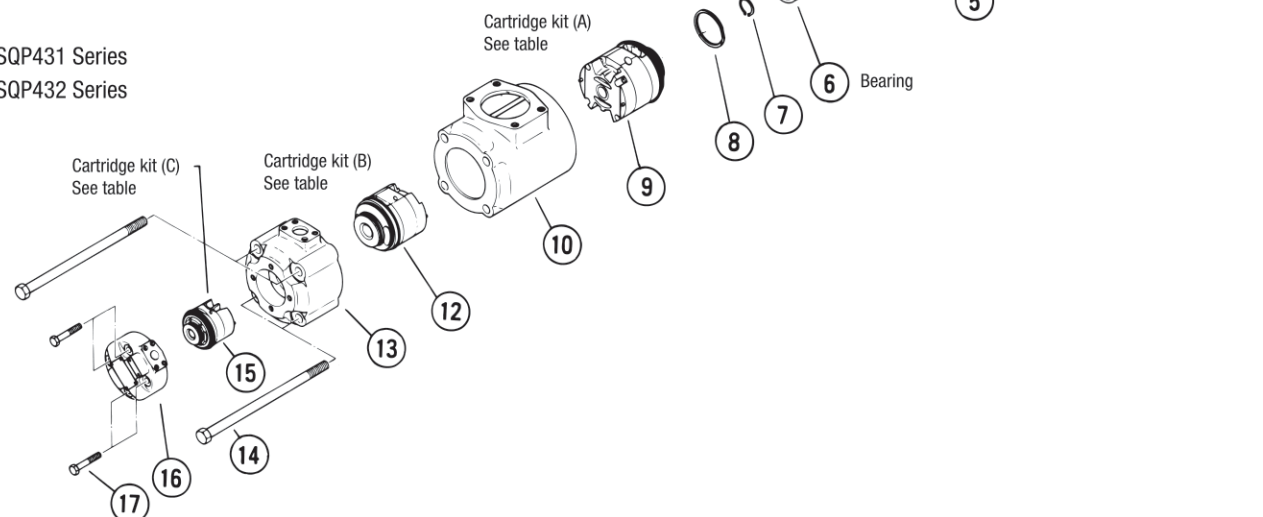

Construction

● Seals, Bearing Table

Series	Seal Kit P/N	Shaft Seal P/N	Bearing P/N
(F11)-SQP211	VA10885A(40028865)	VP191668(40015857)	0070 62051
(F11)-SQP311	VA10757A(40028502)	VP193428(40015856)	0070 63061
(F11)-SQP321	VA10756A(40028503)	VP193428(40015856)	0070 63061
(F11)-SQP421	VA11703A(40028869)	VP195287(40015858)	0070 63071
(F11)-SQP431	VA11133A(40028870)	VP195287(40015858)	0070 63071
(F11)-SQP432	VA11450A(40028871)	VP195287(40015858)	0070 63071

Note: ● Shaft seal included in seal kit.
● Seal kit P/N and shaft seal P/N - () refers to F11.

● Bearing P/N - bold characters refer to JIS B 1521 nominal number.
0070 indicates without shield.

● Cartridge Kit Table

Model Code	For Mineral Oil Based Fluid			For Water Glycol Fluid		
	—	Cartridge Kit B (Middle)	Cartridge Kit C (Cover End)	—	Cartridge Kit B (Middle)	Cartridge Kit C (Cover End)
Displacement Code	—	SQP211	SQP211 SQP311 SQP321 SQP421 SQP431	—	F11-SQP211	F11-SQP211 F11-SQP311 F11-SQP321 F11-SQP421 F11-SQP431
2	—	VA10889A	VA10243A	—	VA12597A	VA12621A
3	—	VA10890A	VA10244A	—	VA12598A	VA12622A
4	—	VA10891A	VA10245A	—	VA12599A	VA12623A
5	—	VA10892A	VA10246A	—	VA12600A	VA12624A
6	—	VA11074A	VA11072A	—	VA12601A	VA12625A
7	—	VA11075A	VA11073A	—	VA12602A	VA12626A
8	—	VA10893A	VA10247A	—	VA12603A	VA12627A
9	—	40018788	(40018789)	—	40018792	(40018793)
11	—	VA10894A	(VA10248A)	—	VA12604A	(VA12628A)
12	—	VA10895A	(VA10249A)	—	VA12605A	(VA12629A)
14	—	VA11455A	(VA11411A)	—	VA12606A	(VA12630A)
Model Code	Cartridge Kit A (Shaft End)	Cartridge Kit B (Middle)	Cartridge Kit C (Cover End)	Cartridge Kit A (Shaft End)	Cartridge Kit B (Middle)	Cartridge Kit C (Cover End)
Displacement Code	SQP211	SQP321 SQP421	SQP432	F11-SQP211	F11-SQP321 F11-SQP421	F11-SQP432
10	VA12087A	VA12100A	VA12106A	VA12553A	VA12607A	VA12631A
12	VA12088A	VA12101A	VA12107A	VA12554A	VA12608A	VA12632A
14	VA12089A	VA12102A	VA12108A	VA12555A	VA12609A	VA12633A
15	VA12090A	VA12103A	VA12109A	VA12556A	VA12610A	VA12634A
17	VA12091A	VA12104A	VA12110A	VA12557A	VA12611A	VA12635A
19	VA12273A	VA12314A	VA12315A	VA12558A	VA12612A	VA12636A
21	VA12092A	VA12105A	40078070	VA12559A	VA12613A	VA12637A
Model Code	Cartridge Kit A (Shaft End)	Cartridge Kit B (Middle)	—	Cartridge Kit A (Shaft End)	Cartridge Kit B (Middle)	—
Displacement Code	SQP311 SQP321	SQP431 SQP432	—	F11-SQP311 F11-SQP321	F11-SQP431 F11-SQP432	—
17	VA12260A	VA12316A	—	VA12560A	VA12614A	—
21	VA12118A	VA12317A	—	VA12561A	VA12615A	—
25	VA12058A	VA12318A	—	VA12562A	VA12616A	—
30	VA12059A	VA12319A	—	VA12563A	VA12617A	—
32	VA12119A	VA12320A	—	VA12564A	VA12618A	—
35	VA12060A	VA12321A	—	VA12565A	VA12619A	—
38	VA12061A	VA12322A	—	VA12566A	VA12620A	—
Model Code	Cartridge Kit A (Shaft End)	—	—	Cartridge Kit A (Shaft End)	—	—
Displacement Code	SQP421 SQP431 SQP432	—	—	F11-SQP421 F11-SQP431 F11-SQP432	—	—
30	VA11211A	—	—	VA12567A	—	—
35	VA12122A	—	—	VA12568A	—	—
38	VA11212A	—	—	VA12569A	—	—
42	VA11213A	—	—	VA12570A	—	—
50	VA11214A	—	—	VA12571A	—	—
60	VA11215A	—	—	VA12572A	—	—

Note: ● Care should be taken as construction of shaft end, middle, and cover end pump differ.
● Cartridge kit includes seals excluding shaft seal.
● "L" is added as suffix to cartridge kit P/N for left hand rotation cartridge kit.

● Some series of cartridge kit P/N's indicated by () may not be applicable.
Confirm displacement codes on page B3-2.