

Variable Displacement Piston Pumps

VARIABLE DISPL. PISTON PUMP - P**V SERIES

Model	Max. WkgPress MPa	Max. Speed min ⁻¹	Displacement cm ³ /rev										Page				
			1	2	3	4	5	10	20	50	100	200					
P16V	21	1800								16							
P21V											21						
P31V												31					
P40V												40					
P70V													70				
P100V														100			
P130V															130		

The P**V Series high performance variable axial piston pump offers a wide range of displacements, a wealth of features, energy-saving design, low noise, high speed, electronics compatibility to meet the diverse needs of users in the machine tool, general industrial machinery, mobile construction markets, etc.

- Low noise: approx. 68.5dB(A) [P70V] at pressure, 21 MPa and speed, 1800 min⁻¹.
- Offers many types of pump control functions: (single stage, multi-stage, proportional) pressure compensator control, load sensing control, self-pressurized dual pressure dual flow control, electric direct control, etc. In addition, configurations which include manifold blocks which incorporate various function valves can be mounted at the delivery port, with a capacitor-like function which reduces pulsations are possible which simplify hydraulic circuits and reduce noise.

Var. Piston Pump Principle of Operation

Delivery side: Pistons pushed against swash plate

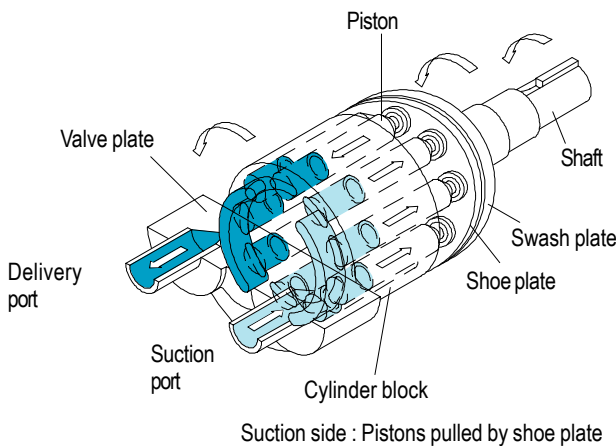

Control Example (Pressure Compensator)

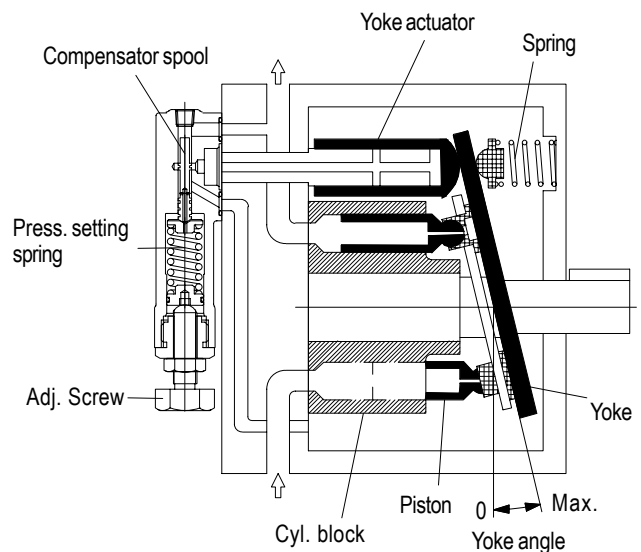

When Pump del. Pressure approaches setting pressure. compensator spool is actuated and pressurized oil is fed to control piston which acts to reduce pump delivery

HIGH PRESSURE VARIABLE DISPL. PISTON PUMP PH SERIES

Model	Max. WkgPress MPa	Max. Speed min ⁻¹	Displacement cm ³ /rev								Page		
			1	5	10	20	50	100	200				
PH Series	PH80	*1 Rated pressure 28	1800							80			A21
	PH100	*2 Intermittent pressure 30									100		
	PH130										130		

NOTE: *1 Intermittent pressure refers to less than 10% of operating cycle (max.6 seconds).

Consult Tokimec for working pressure above rated pressure.

*2 Rated pressure of electro-direct control EDHS pump is 21 MPa which is set by the relief valve.

The PH Series is a 28 MPa-rated low noise variable axial piston pump in a compact configuration.

* Low operation noise: highly rigid pump construction and proprietary noise reduced design enables low operational sound levels.

* Long life: high efficiency design with 28MPa rated pressure

* Superior controllability: in addition to pressure compensator control, load sensing control, and electric direct control, torque limiter control is also offered.

* Wide array of configuration: direct coupled same displacement double pump, direct coupled fixed double, triple pump combinations

Var. Piston Pump Principle of Operation

Delivery side: Pistons pushed against swash plate

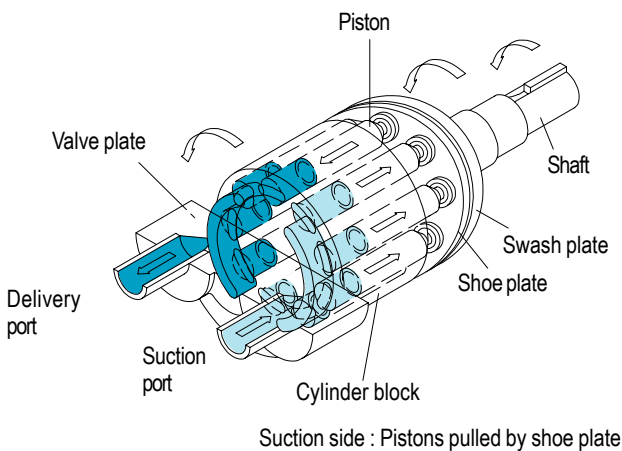

Suction side : Pistons pulled by shoe plate

Control Example (Pressure Compensator)

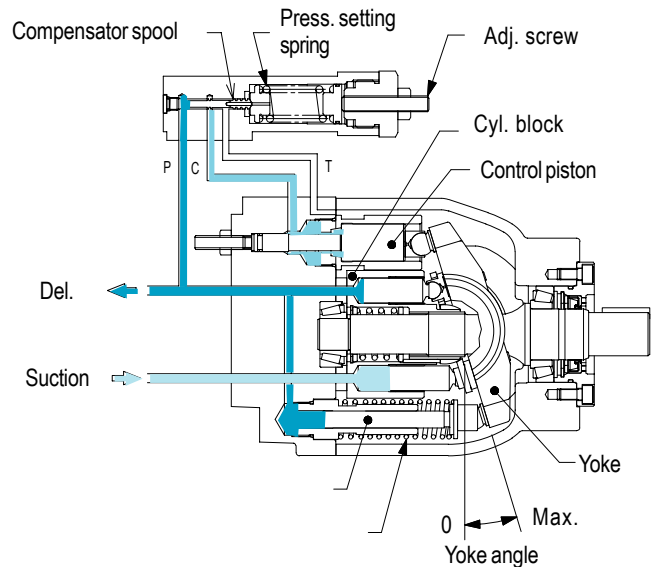

When pump del. Pressure approaches setting pressure. Compensator spool is actuated and pressurized oil is fed to control piston which acts to reduce pump delivery

Notes On Operation

Installation and Shaft Alignment

- The space for the electric motor and pump should offer sufficient rigidity. Vibration absorbing construction is recommended.
- Flexible type coupling is recommended to join the drive shaft of the prime mover and the pump shaft. (However use of tire shaped coupling is NOT RECOMMENDED.)
- Recommended shaft alignment value, TIR (Total Indicator Reading) is below 0.05mm. However this may differ according to type of coupling used and coupling method employed. Please consult with TOKIMEC regarding shaft alignment value in this case.
- Poor shaft alignment may cause shaft damage, heat and friction of bearings, leakage from oil seals, pump noise and vibration, etc. Thus shaft should be aligned with care.
- In principle, there should be no external radial or thrust loads on the shaft end. Please consult with TOKIMEC is belts, chains, or gears are to be used to drive the pump.
- Care should be paid that no air remains in the pump case. Pump should be mounting with drain port up. Pump shaft should be installed horizontally.

Piping and Filtration

- Filtration
On the suction side, a 100 μ m (150 mesh) or equivalent tank filter (suction filter) should be used. On the delivery side, a bypass filter which provides filtration of less than 20 μ m should be installed.
- Suction pressure (gauge pressure)
For mineral oil based fluids pressure should be in the range +35 ~ -16.7kPa and for water glycol, +35 ~ -10.1kPa.

- Suction path flow velocity should be kept at less than max. 1.5 m/s.
- Suction, return piping
 - Stipulated suction pressure should be considered and suction resistance should be kept as low as possible.
 1. Use large diameter pipe with as few bends as possible.
 2. Height from pump suction port to tank standard oil level should be less than 1m.
 - Distance from suction piping end to tank bottom should be more than 50mm.
 - Air in system causes noise, vibration, and parts damage. As air can easily be drawn in through suction piping, care should be paid to insure that joints, especially, are airtight.
 - A baffle should be installed in the tank between the suction and return lines.
 - Use of flexible rubber hose piping instead of steel piping for pump suction, delivery, and drain lines provides effective vibration dampening and reduces noise.
- Drain piping
 - Pressure in pump case should not exceed 50kPa. Drain piping should be installed on the upward side of the pump and the pump case should always be filled with oil.
 - Drain line should be led to tank separate and should not be mixed with the flow from the return piping and should be installed so that it is set apart from the suction pipe and should also extend below the oil level in the tank.

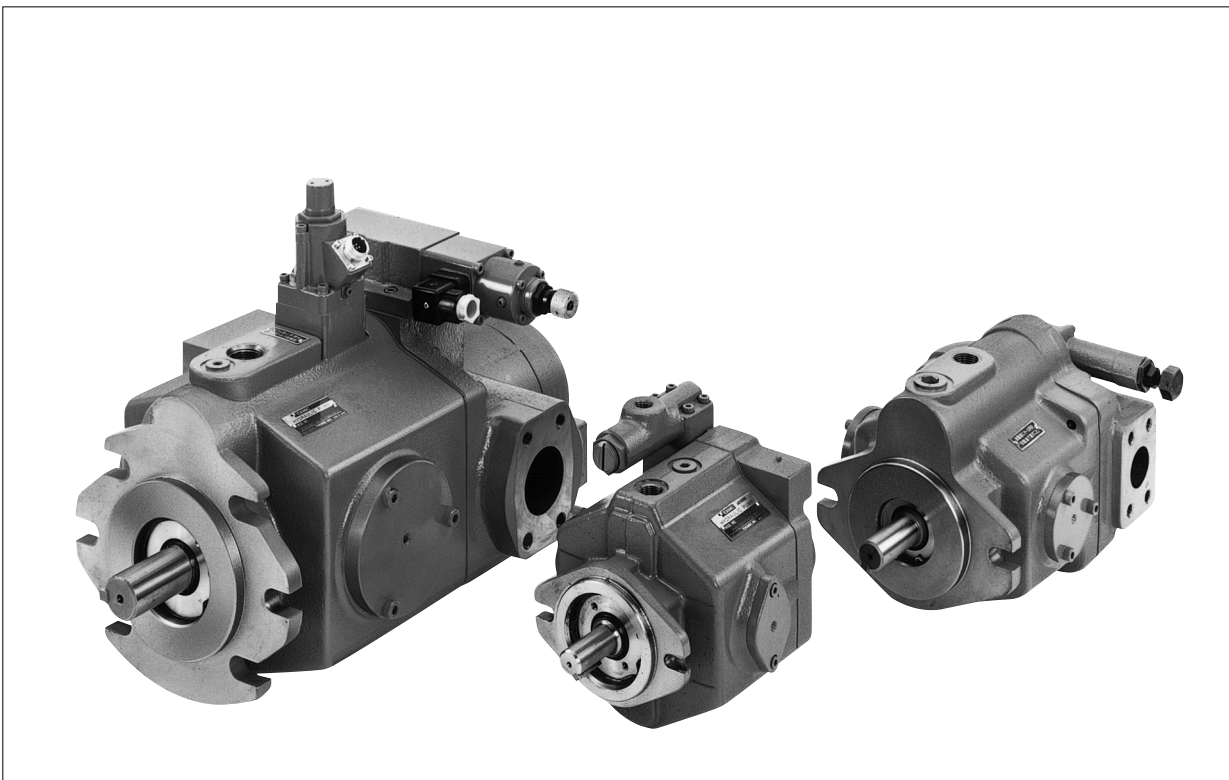

Operation Start-Up

• Filling oil

Pump should be filled with clean oil through the drain port and fill ports and the pump case should be filled completely. Improper or insufficient oil filling will lead to pump problems.

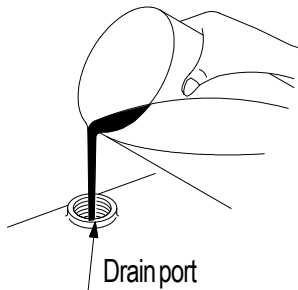

Model	Displ. mL
P16V	700
P21/31V	800
P40V	1000
P70V	1500
P100V	2000
P130V	2300
PH80	1600
PH100	2500
PH130	3700

• Air bleed

At startup of pump operation, pump should be run at no load, maximum flow until air is completely bled from piping and pump case. Effective air bleed can be accomplished if an air bleed valve is installed on the pump delivery side. For details on the air bleed valve, see page R5.

• Warm up

If oil viscosity is above the recommended $54\text{mm}^2/\text{s}$, run pump at less than 1/2 maximum working pressure to warm the hydraulic fluid.

Hydraulic fluid

• Note that pump specifications such as maximum working pressure and maximum speed may differ with the type of hydraulic fluid used. See Attachment 1 regarding hydraulic oil selection.

• Mineral based oil

– General industrial anti-wear hydraulic fluid is recommended.

• Water glycol based hydraulic oil

– Do not use this fluid with the standard pump intended for mineral oil based fluids.

– Consult TOKIMEC regarding specifications for pump using this fluid.

Hydraulic fluid viscosity and temperature

• Pump should be operated with hydraulic fluid viscosity range of $13 \sim 54 \text{mm}^2/\text{s}$.

At pump startup a maximum viscosity of $860 \text{mm}^2/\text{s}$ is allowed however care should be paid to observe the section 'Cautions at Operation Startup' regarding warm up of hydraulic fluid.

• Hydraulic fluid temperature range should be $0 \sim 60^\circ\text{C}$.

Pump Control Adjustment

• Pressure compensator control

Turning the compensator adjustment screw clockwise will increase the setting pressure, turning it counterclockwise will decrease the setting pressure.

* Maximum displacement adjustment function

This function allows adjustment of full flow displacement. Turning the adjustment screw clockwise will decrease the full flow displacement, turning the screw counterclockwise will increase the displacement.

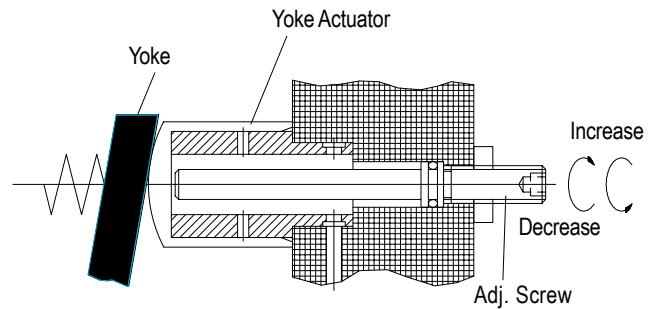

○ Max. displ. adjuster

• Torque limiter control

This function adjusts delivery volume to match the allowable load of the electric motor used to drive the pump. Turning the adjustment screw clockwise will increase the delivery and turning the screw counterclockwise will decrease the delivery.

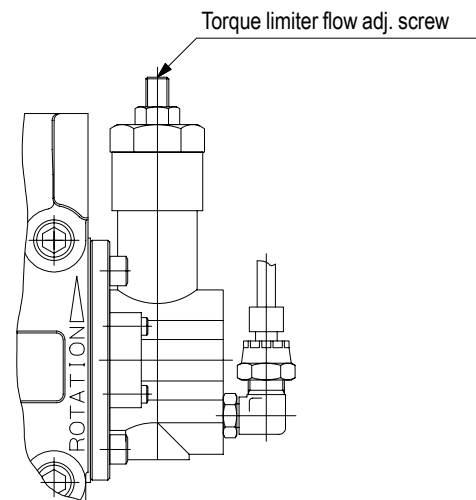

Low Noise Variable Displ. Piston Pumps P**V Series

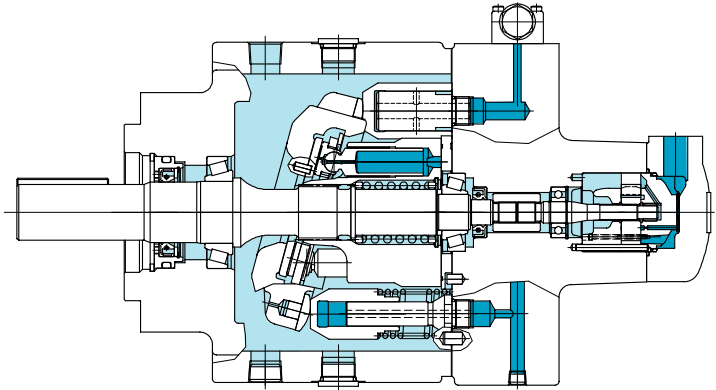
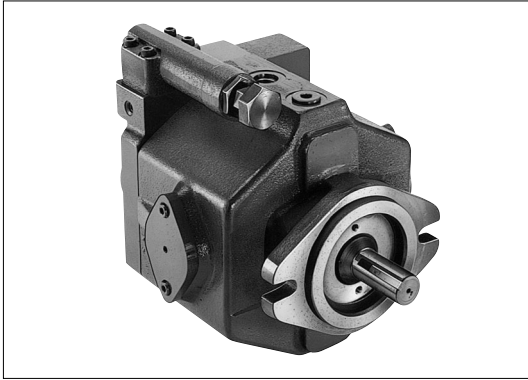

This pump series offers low noise, high performance, and reliability with various functions for fast response and stability with a variety of controls such as electric direct control, pressure compensator, and load sensing. Double pump configurations to meet system needs are also available. These pumps are ideal for customer needs for energy saving, high speed, and low noise.

Symbol

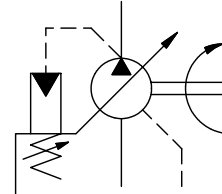

Model Code

P16V - (F)RS(G) - 11 - CCG - 10 - J

1 2 3 4 5 6 7 8

- | | |
|---|---|
| <p>1 Swash plate type variable piston pump
P**V Series</p> <p>2 Pump mounting
Omitted : flange mounting
F : foot bracket</p> <p>3 Rotation (viewed from shaft end)
R : right rotation(clockwise)
L : left rotation(counterclockwise)</p> <p>4 Displacement
S : one side of center</p> <p>5 Porting(drain port to JIS tapered th fd)
Omitted : SAE O-ring seal
G : SAE 4 bolt flange</p> <p>6 Design no.</p> | <p>7 Controls
C : pressure compensator (1.5 ~ 21 MPa)
CM : pressure compensator (1.5 ~ 10.5 MPa)
CG : remote pressure compensator
CV : load sensing control
2P : self pressurized, 2press./2flow control
EP : proportional valve press. compensator
*C : Maximum displacement adjustment
(CC,CMC,CCG,CVC)</p> <p>8 Control valve design no.</p> |
|---|---|

Model Code

(F11) - P70V(3)(F)R(62) - (2)(C)11 - EDQS - 10 - J

1	2	3	4	5	6	7	8	9	10	11
---	---	---	---	---	---	---	---	---	----	----

- 1** Fluid
Omitted : mineral oil
F11 : water glycol
- 2** P**V Series
P21V,P31V,P40V,P70V,P100V,P130V
- 3** Double pump code
Omitted : single pump
3 : integrated fixed vane pump
(P40V,P70V,P100V,P130V)
4 : fixed vane pump SQP1 Series
w/thru shaft
(P70V,P100V)*
5 : fixed vane pump SQP2 Series
w/thru shaft
(P70V,P100V,P130V)*
6 : fixed vane pump SQP3 Series
w/thru shaft
(P100V,P130V)*
7 : P16V variable piston pump w/thru shaft
(P40V,P70V,P100V,P130V)
- Consult TOKIMEC regarding displacements, models of SQP1, SQP2, SQP3
- 4** Pump mounting
Omitted : no foot bracket
F : foot bracket
- 5** Rotation (viewed from shaft end)
R : right rotation(clockwise)
L : left rotation(counter-clockwise)
- 6** Maximum displacement limitation
Input max. displacement to be limited.
(example: input 62 in case of 62cm³/rev maximum displacement limitation for P70V)
- 7** Integrated vane pump displacement code
See specifications
- 8** Vane pump delivery port position (input only if 3 is shown under **3**)
Viewed from cover side with control valve up
A : bottom
B : left
C : up
D : right
- 9** Pump design no.
- 10** Controls
C : press.compensator
(P21V,P31V,P40V,P70V,P100V,P130V)
CM : press.compensator
(P21V,P31V,P40V,P70V,P100V,P130V)
CG : remote press. compensator
(P21V,P31V,P40V,P70V,P100V,P130V)
CV : load sensing (P21V,P31V)
CVF : load sensing
(P40V,P70V,P100V,P130V)
CGVF : load sensing w/remote press. compensator
(P40V,P70V,P100V,P130V)
2P : self pressurized, 2press./2flow
(P31V,P40V)
EP : proportional valve press. compensator
(P21V,P31V,P40V,P70V,P100V,P130V)
MC1U : multi-stage press. compensator
[1press. unload]
(P21V,P31V,P40V,P70V,P100V,P130V)
MC2 : multi-stage press.compensator
[2pressures]
(P21V,P31V,P40V,P70V,P100V,P130V)
MC2U : multi-stage press. compensator
[2press. unload]
(P21V,P31V,P40V,P70V,P100V,P130V)
MC3 : multi-stage press. compensator
[3pressures]
(P21V,P31V,P40V,P70V,P100V,P130V)
*C : Maximum displacement adjustment
(CC,CMC,CCG,CVC,MC1UC,
MC2C,MC2UC,MC3C)
EDQS : elec.direct control [flow]
(P40V,P70V,P100V,P130V)
EDS : elec.direct control [flow,pressure]
(P40V,P70V,P100V)
- 11** Control valve design no.

Specifications

Model	Max. Displ. cm ³ /rev	Max. Pressure MPa	Max. Speed min ⁻¹	Min. Speed min ⁻¹	Weight kg
P16V	16	21	1800	600	15
P21V	21				23
P31V	31				23
P40V	40				37
P70V	70				63
P100V	100				91
P130V	130				112

- Weights are for pumps with pressure compensator.
- Consult TOKIMEC for specifications of pumps using water glycol fluids.

Integrated vane pump specifications

7 Displ. Symbol	Displacement cm ³ /rev	Max. Working Press. MPa
2	6.3	16
3	9.4	
4	12.5	
5	15.6	

Controls

Pump Control Method		Characteristics Curve	Remarks	Symbol
Type	Code			
Pressure Compensator	C		<ul style="list-style-type: none"> When delivery pressure approaches the compensator setting, pump delivery is automatically reduced to the minimum flow necessary to maintain the pressure. Setting pressure may be adjusted manually. 	
	CM			
Dual pressure, dual flow self-pressured control	2P		<ul style="list-style-type: none"> Dual pressure compensation control enables automatic switching from low pressure-high flow to high pressure-low flow modes. 	
Remote pressure compensator	CG		<ul style="list-style-type: none"> Setting pressure of pressure compensator control can be set from a separate location with a remote control valve. 	
Proportional pressure compensator	EP		<ul style="list-style-type: none"> Variable proportional setting of pressure with the integrated electro-proportional control valve. 	
Load sensing control	CVF (CV)		<ul style="list-style-type: none"> Automatically controls pump flow to maintain a fixed differential pressure across flow control valve downstream of the pump. Energy saving. Provides min. flow and pressure to drive the load (actuator). Figure at right is of CVF control. 	
Remote load sensing control w/pressure compensator	CGVF		<ul style="list-style-type: none"> Pump delivery automatically controlled with load sensing control during flow control. Pump control automatically switches as pump delivery pressure approaches pressure compensator setting (cutoff pressure). 	

Pump Control Method Type		Code	Characteristics Curve	Remarks	Symbol
Multi-stage pressure compensator control	MC1U		<p>注)ソレノイドOFFの時はアンロードです。</p>	<ul style="list-style-type: none"> Selection of control of unload and pressure compensator setting pressure with solenoid valve integrated on pump. 	
	MC2			<ul style="list-style-type: none"> Two compensator setting switching with solenoid valve integrated on pump. 	
	MC2U		<p>注)ソレノイドOFFの時はアンロードです。</p>	<ul style="list-style-type: none"> Unload and two pressure settings of compensator with solenoid valve integrated on pump. 	
	MC3			<ul style="list-style-type: none"> 3-pressure compensator settings switched by solenoid valve integrated on pump. 	
Electrical direct control	EDQS			<ul style="list-style-type: none"> Position sensor mounted on pump detects swash plate angle provides linear control of delivery flow in response to flow control signal. 	
	EDS			<ul style="list-style-type: none"> In flow control mode, pump delivery is controlled by flow control signal. When pump delivery pressure approaches pressuring setting signal, mode automatically switches to pressure control. 	

Pump Control Method		Characteristics Curve	Remarks	Symbol
Type	Code			
Maximum displacement adjustment function	*C **C		<ul style="list-style-type: none"> • Maximum displacement adjustment with adjustment screw on pump. • Pressure control characteristics dependent on ** section control method. 	<p>Displacement adjuster symbol</p>

Max Displacement Adjuster Characteristics

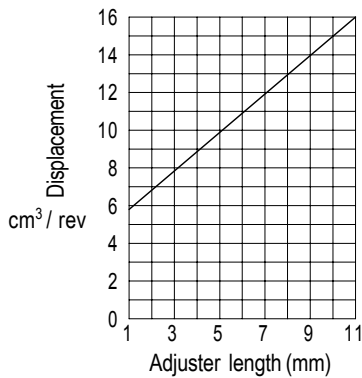

P16V Series

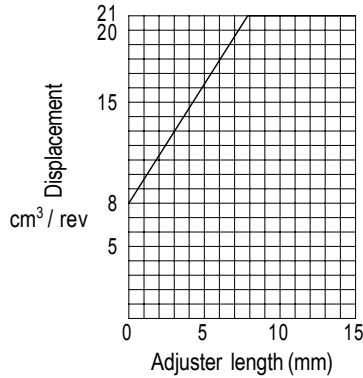

P21V Series

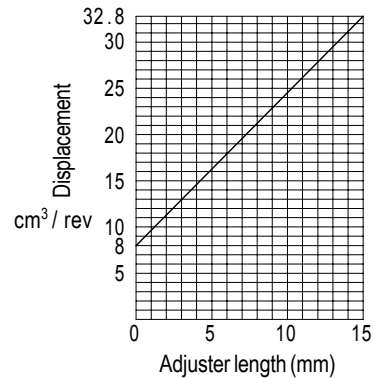

P31V Series

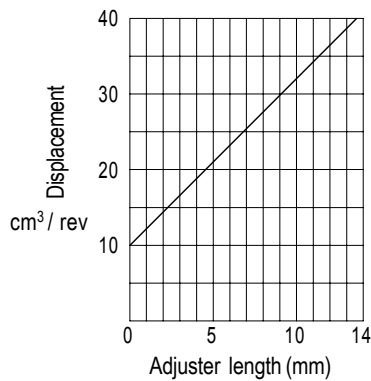

P40V Series

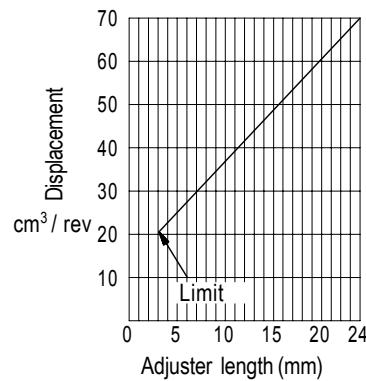

P70V Series

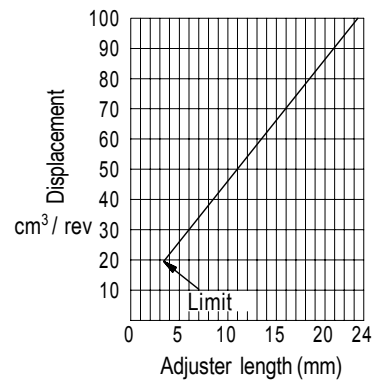

P100V Series

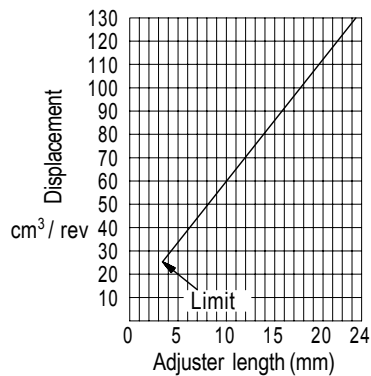

P130V Series

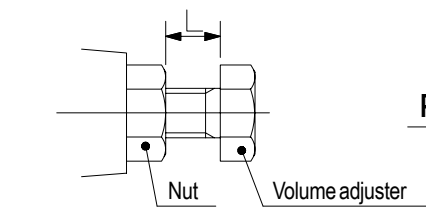

P16V Series

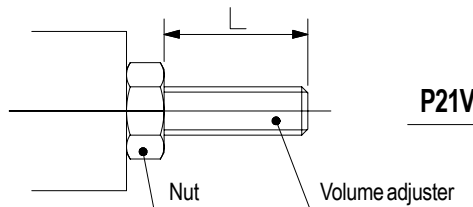

P21V~P130V Series

Characteristics Curves (at 20 mm²/s)

Pressure, efficiency, delivery, input power (1800 min⁻¹)

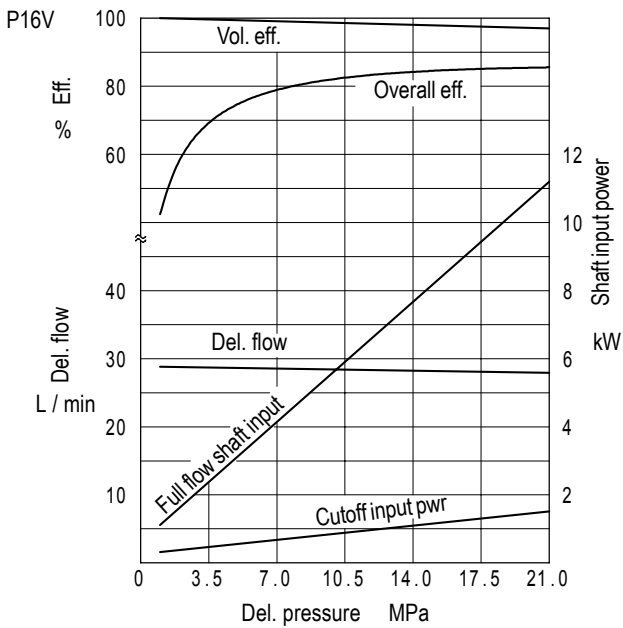

Pressure, noise characteristics (1m from pump rear)

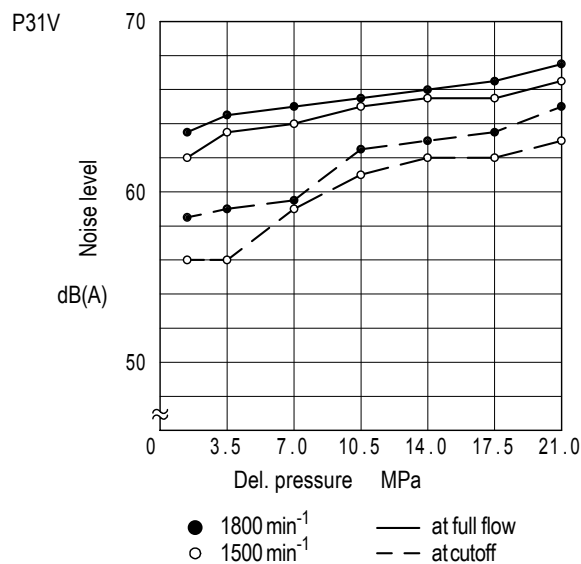
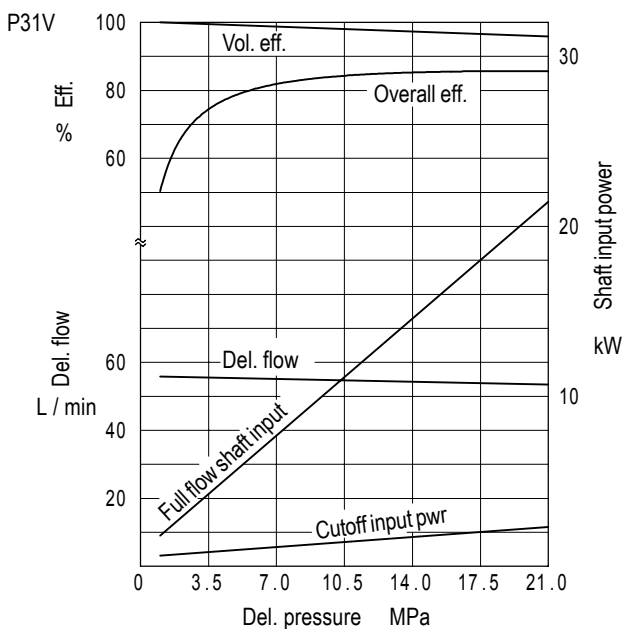
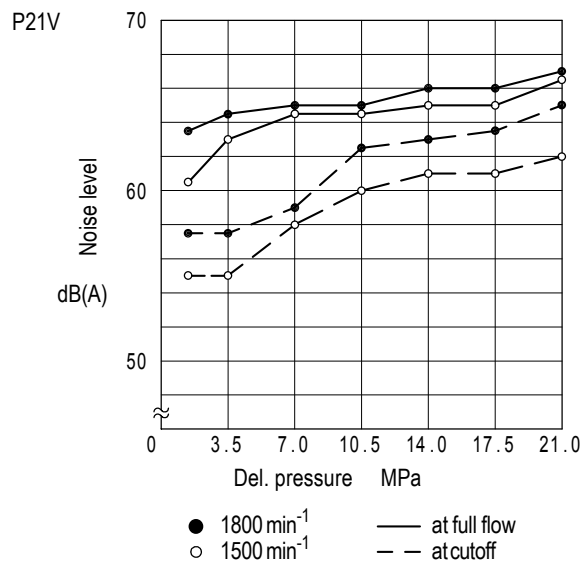
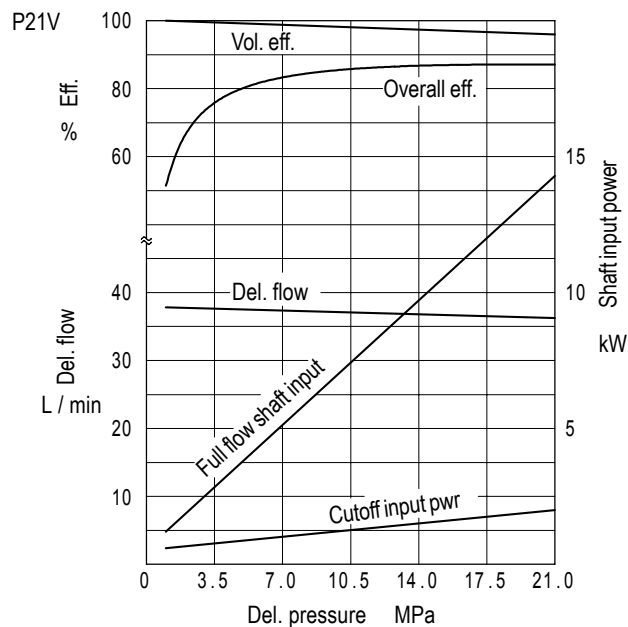
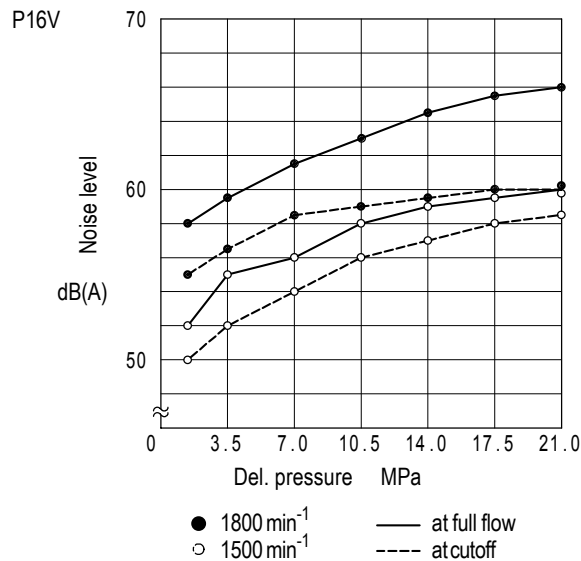

Characteristics Curves (at 20 mm²/s)

Pressure, efficiency, delivery, input power (1800 min⁻¹)

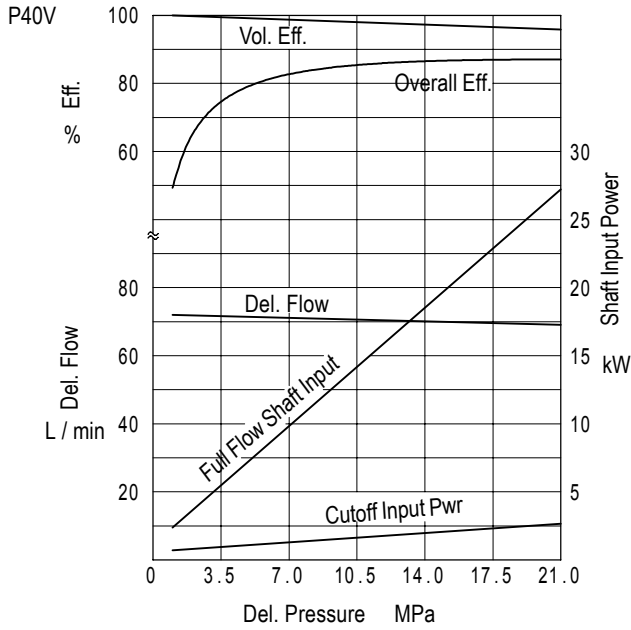

Pressure, noise characteristics (1m from pump rear)

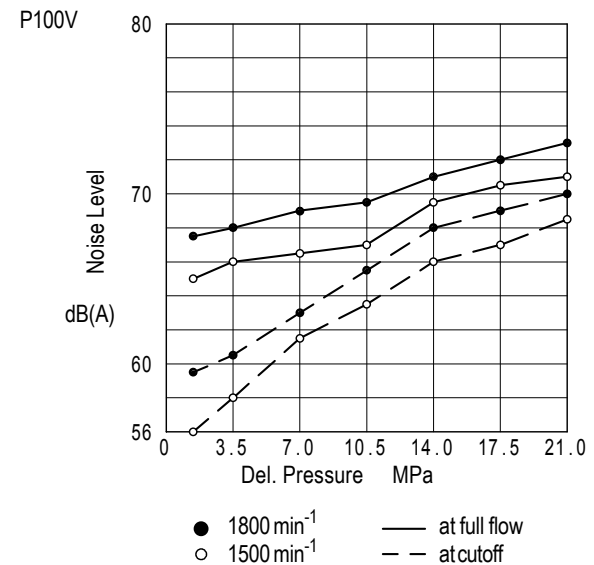
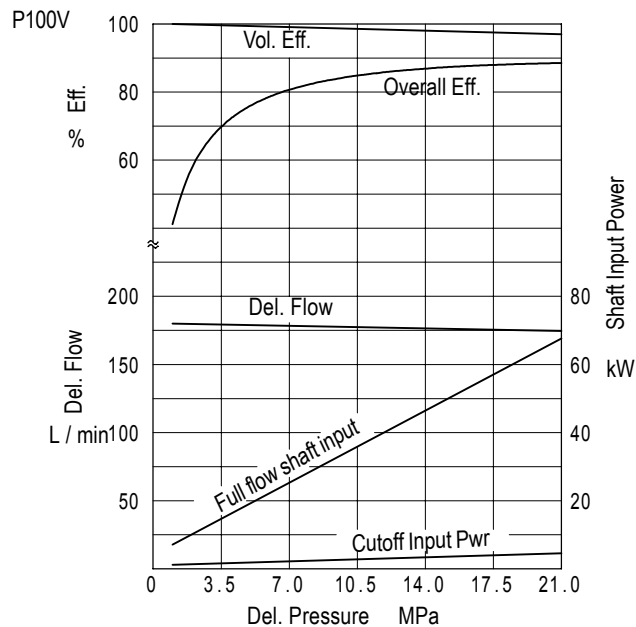
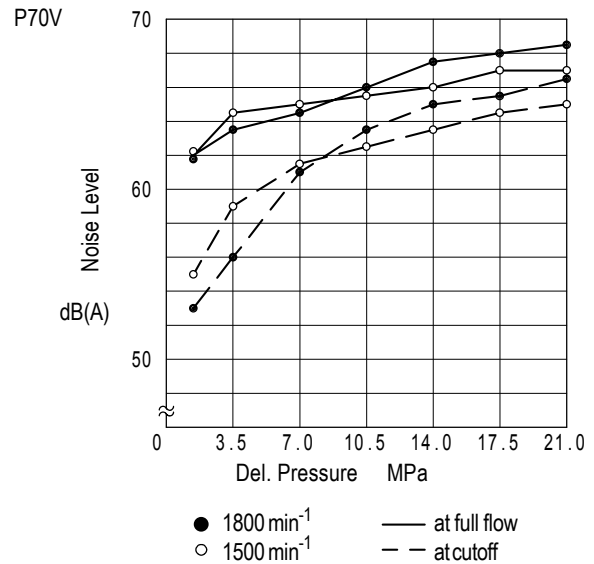
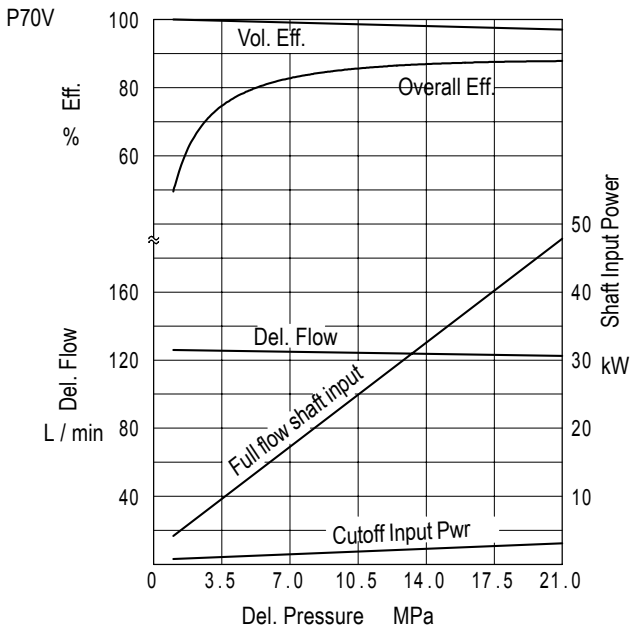
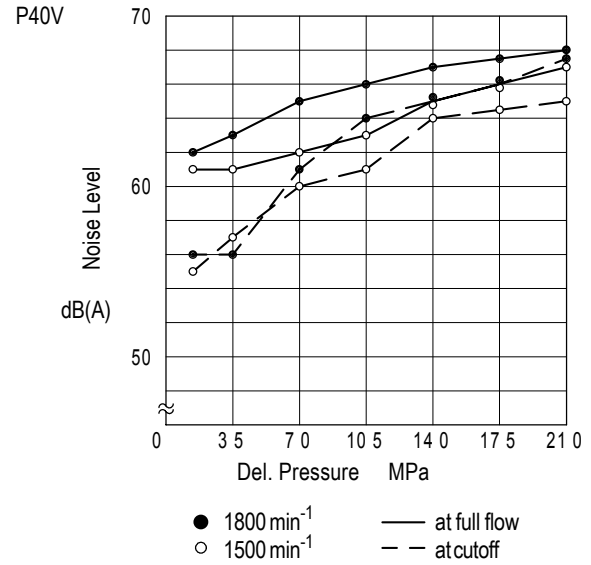

Characteristics Curves (at 20 mm²/s)

Pressure, efficiency, delivery, input power (1800 min⁻¹)

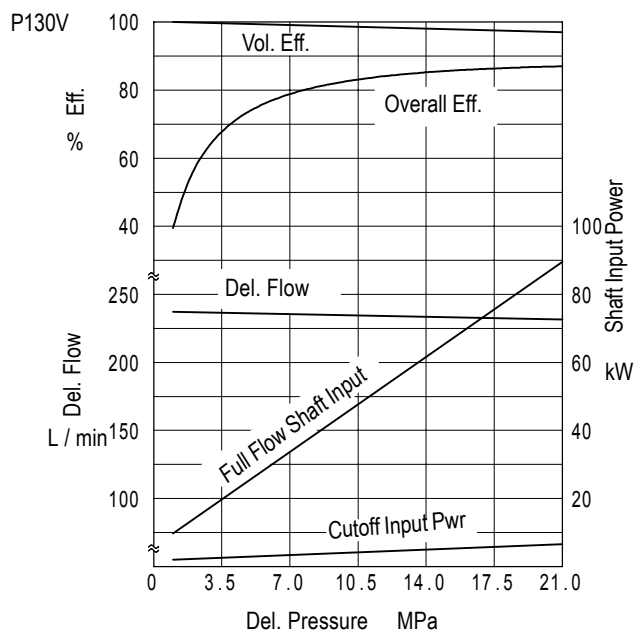

Pressure, noise characteristics (1m from pump rear)

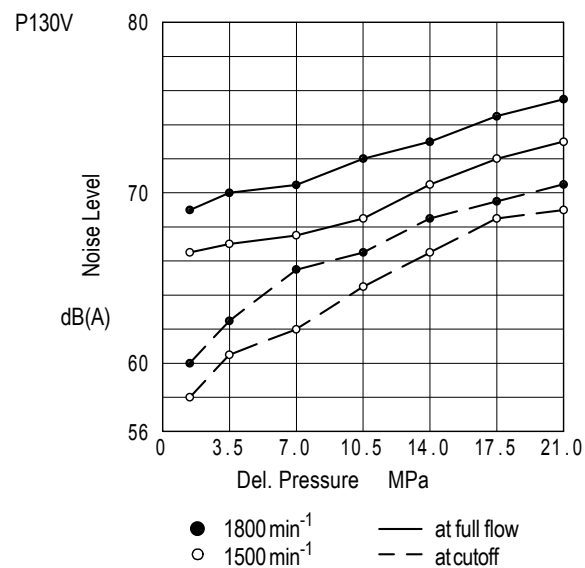

Pressure, drain characteristics (at 1800 min⁻¹, 20 mm²/s)

AT FULL FLOW

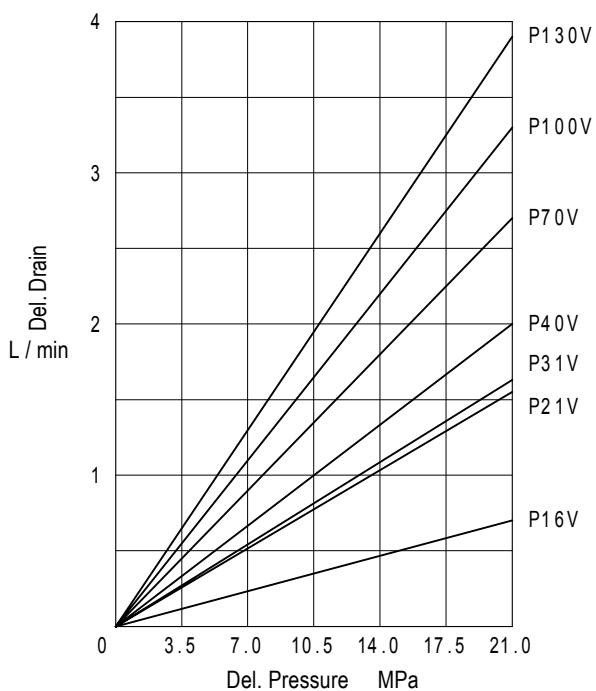

AT CUTOFF (C:Pressure Compensator)

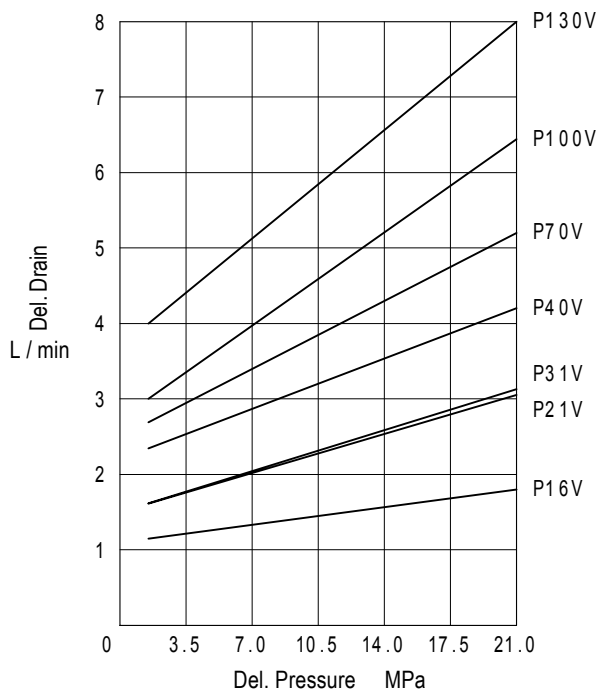

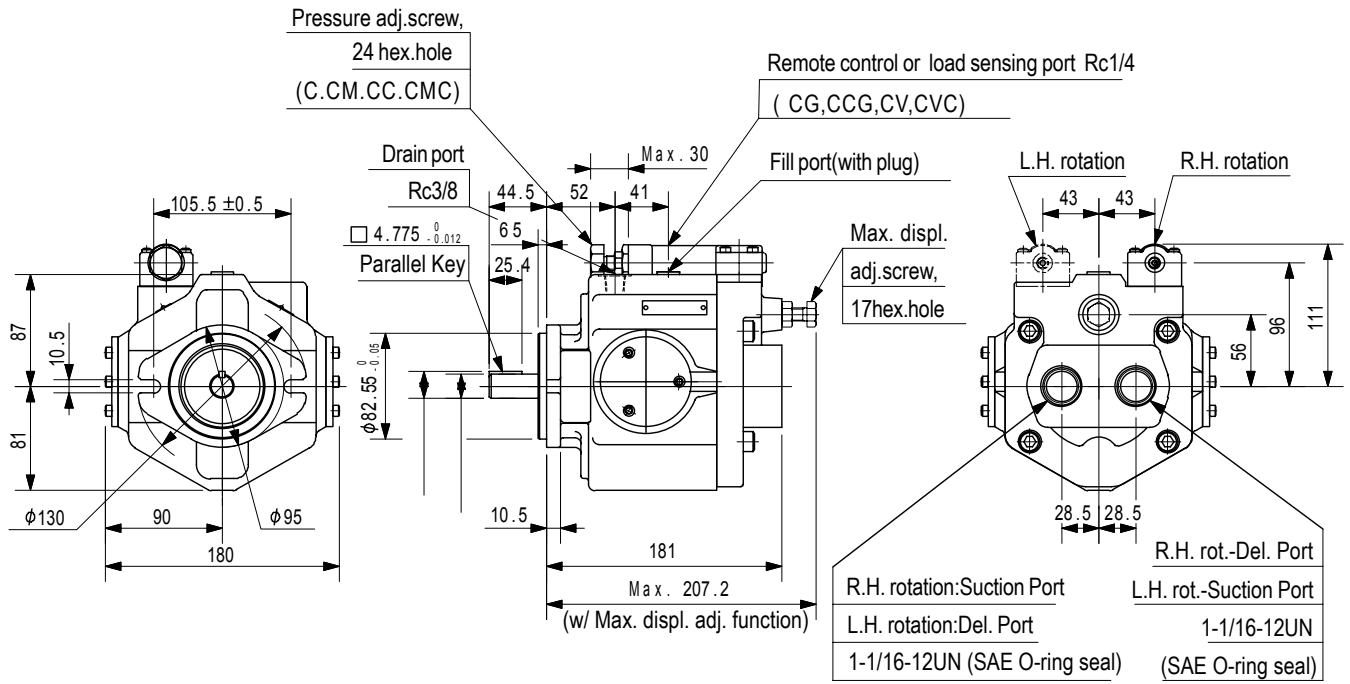

FOOT MOUNT

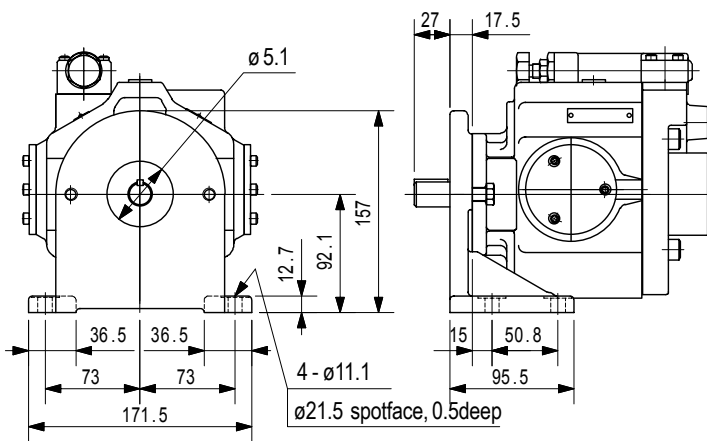

PORTING "G"

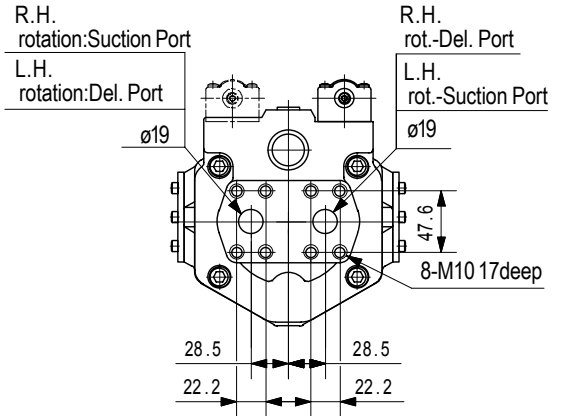

P21V / P31V

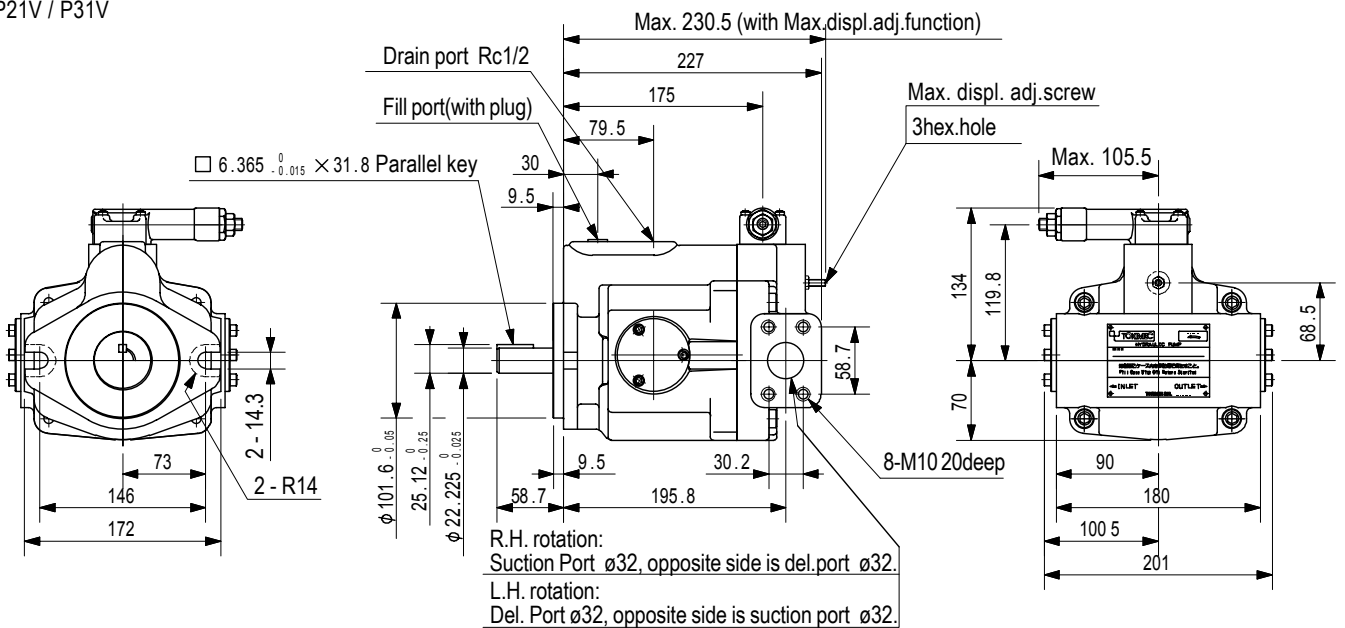

Dimensions

P40V

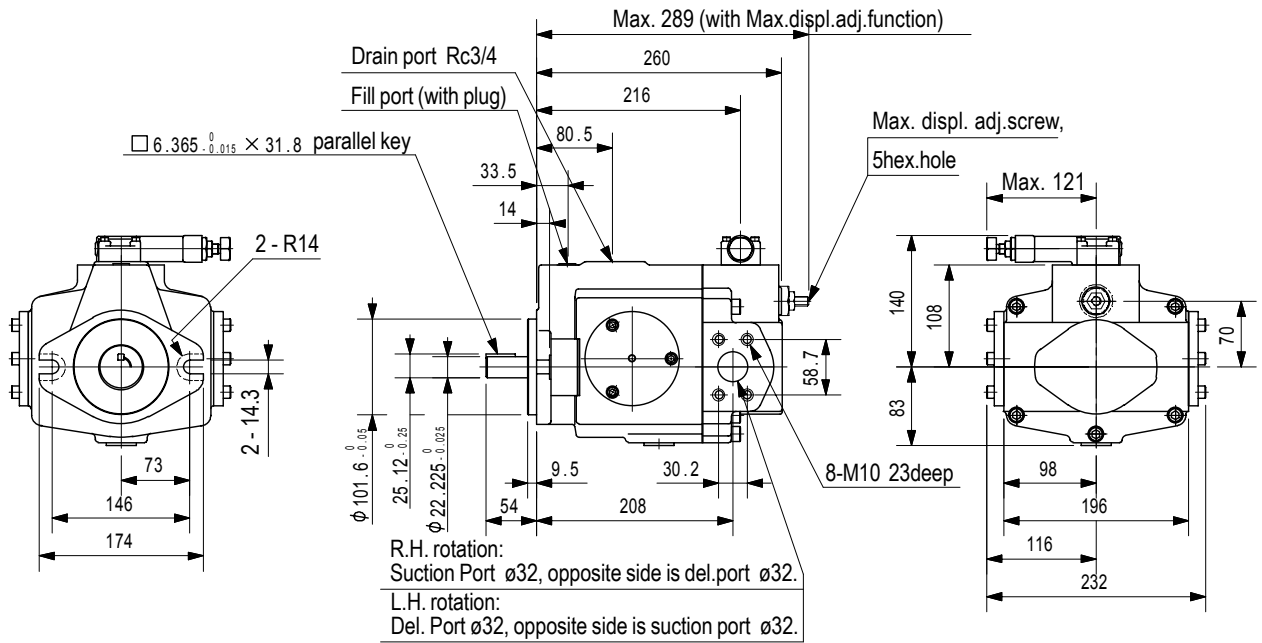

P70V

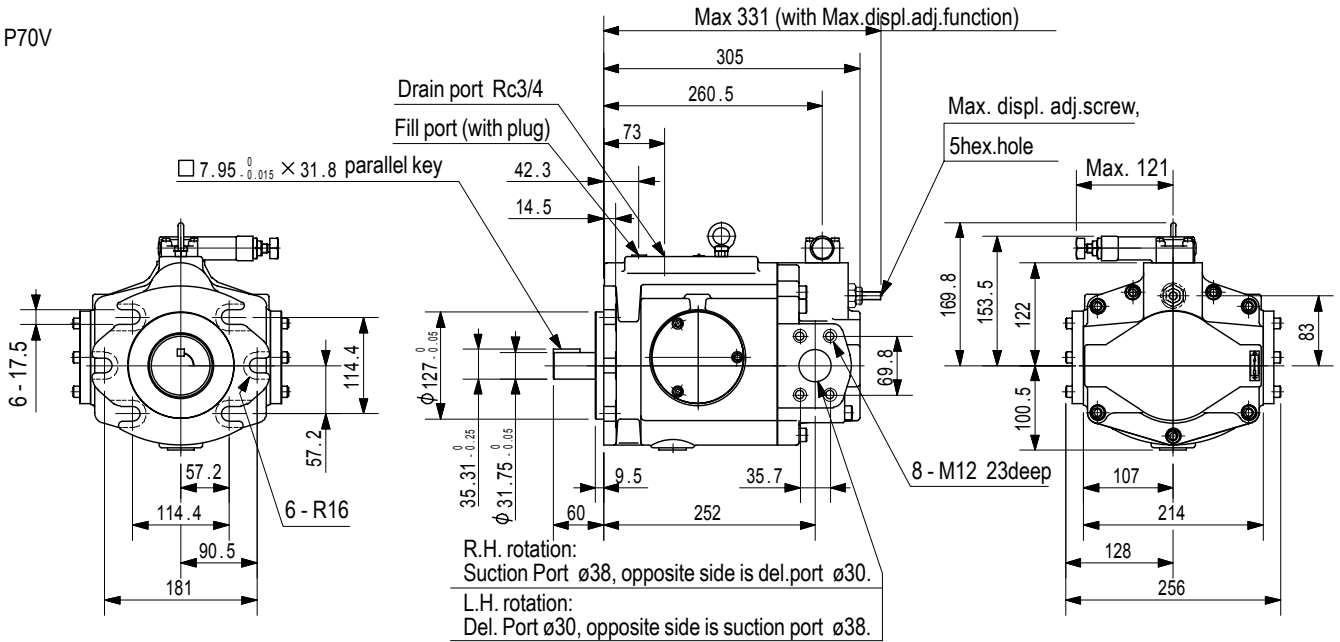

P70V3

NOTE:
The dimension same as P70V(except as were noted)

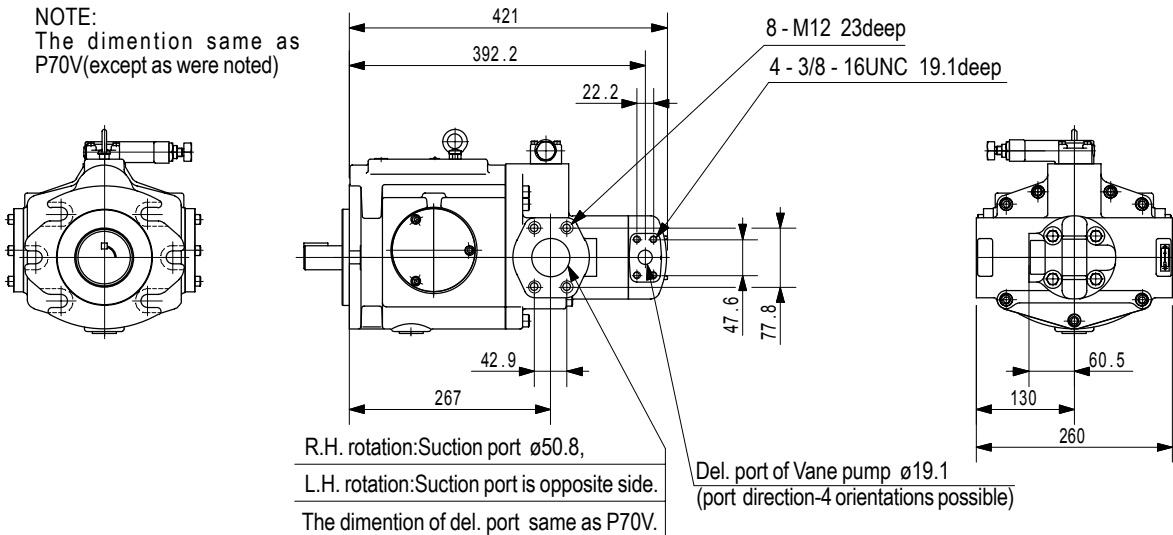

P100V

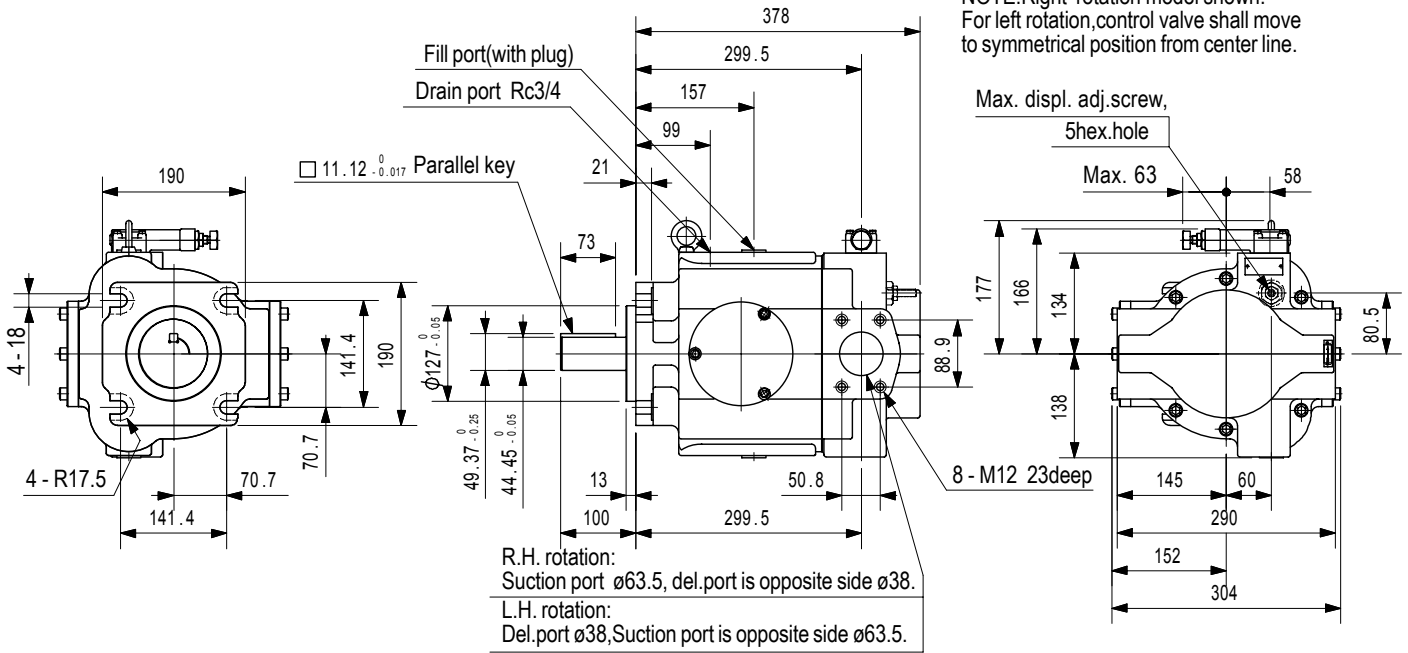

P100V3

NOTE: The dimensions same as P100V. (except as were noted)

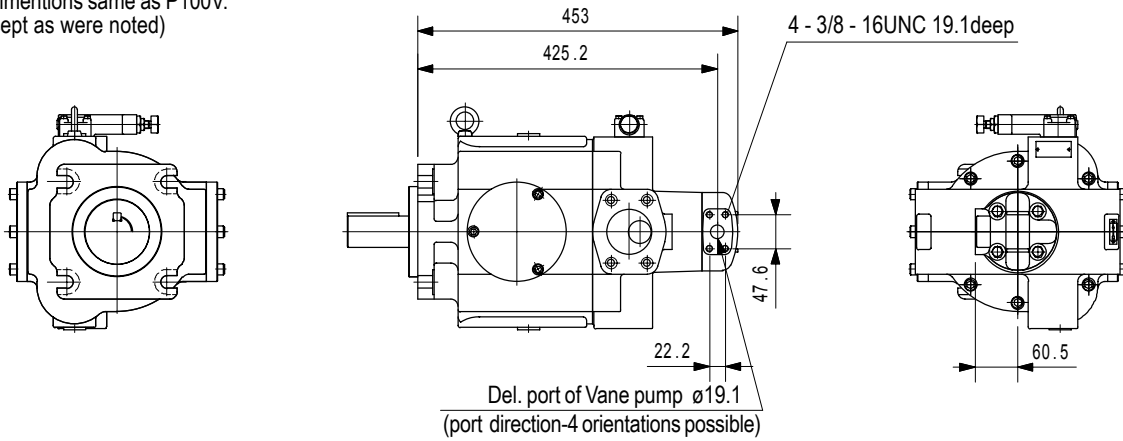

P130V

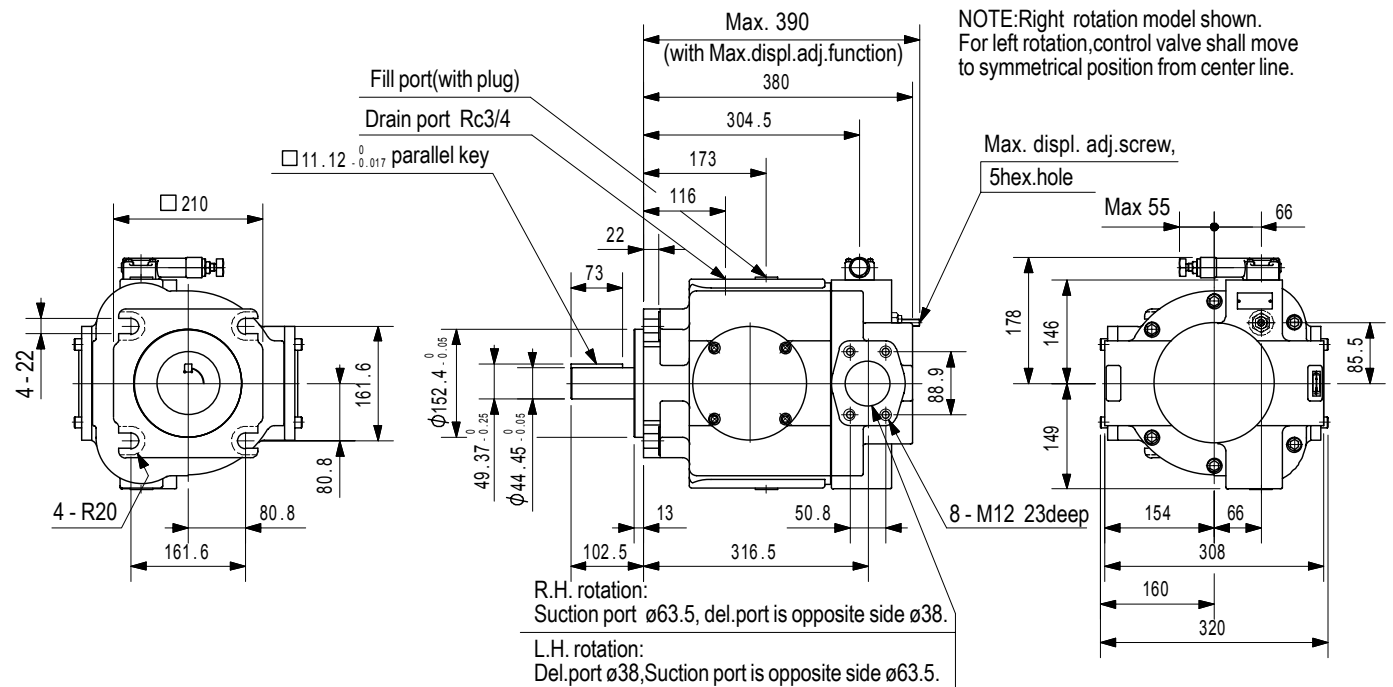

Dimensions

P130V3

Note : Dimensions same as P130V except as were noted

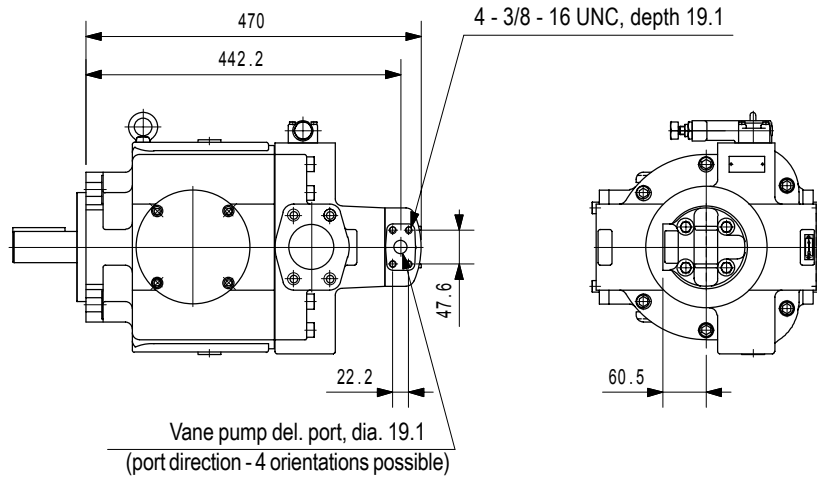
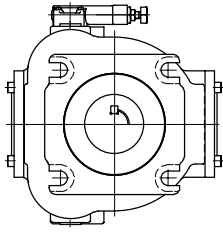

Notes on Operation

- See piston pump Notes on Operation (page A4, A5)

Piping Flanges and Couplings

- Flanges and couplings must be ordered separately. See table below for required parts.

Piping Flanges (conforming to SAE J518c standard flanges)

Pump Model	Threaded		Welded		
	Diameter	Flange Model	Diameter	Flange Model	
P16V	Rc3/4	FL1-6-06P-10-JA-S4-M	20A	FL1-6-06W-10-JA-M	
P21V,P31V P40V	Rc1-1/4	FL1-10-10P-10-JA-S4-M	32A	FL1-10-10W-10-JA-M	
P70V	Rc1-1/2	FL1-12-12P-10-JA-S4-M	40A	FL1-12-12W-10-JA-M	
P70V3	Del.	Rc1-1/2	FL1-12-12P-10-JA-S4-M	40A	FL1-12-12W-10-JA-M
	Suction	Rc2	FL1-16-16P-10-JA-S4-M	50A	FL1-16-16W-10-JA-M
P100V(3) P130V(3)	Rc2-1/2	FL1-20-20P-10-JA-S4-M	65A	FL1-20-20W-10-JA-M	

- Integrated vane pump delivery port flange

Threaded		Welded	
Diameter	Flange Model	Diameter	Flange Model
Rc3/4	FL1-6-06P-10-JA-S4-J	20A	FL1-6-06W-10-JA

- Flange includes O-rings, mounting bolts, spring washers

Pipe Couplings (SAE O-ring seal couplings)

Pump Model	Suction, delivery port couplings		
	Pump side thread size	Piping side thread size	Part no.
P16V	1-1/16-12UN	Rc3/8	VPA36051
		Rc1/2	VPA36873
		Rc3/4	VPA31817
		Rc1	VPA39410

Construction

P16V

Item	Name	Part No.	Standard	Qty
3	O-ring	007990619	AS568-906(NBR,Hs90)	1
7	O-ring	007991619	AS568-916(NBR,Hs90)	2
9	Shaft seal	VA29405		1
19	Gasket	VA29431		1
28	O-ring	008000617	JIS B 2401 1A-P8	1

Seal kit P/N : VA12268A
 Rotating group kit 18 P/N : VA14144A

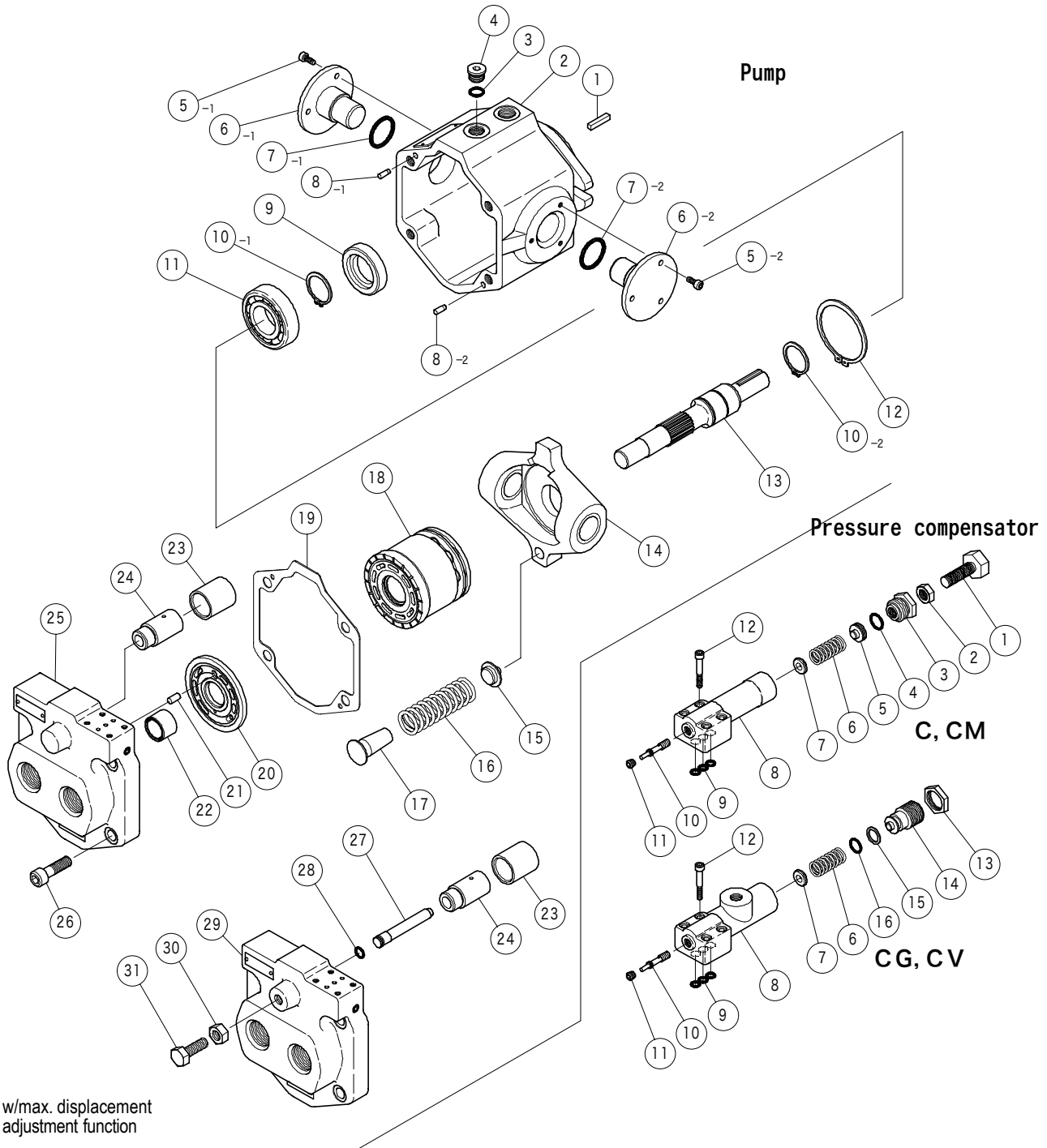

w/max. displacement
 adjustment function

Item	Name	Part No.	Standard	Qty
4	O-ring	007901517	AS568-015(NBR,Hs70)	1
9	O-ring	007901019	AS568-010(NBR,Hs90)	3
15	Backup ring	40022325		1
16	O-ring	007911217	AS568-112(NBR,Hs70)	1

Construction

P21V,P31V,P40V,P70V
P21V/P31V

Item	Name	Part No.	Standard	Qty
5	Shaft seal	VA29405	—	1
7	O-ring	007990619	AS568-906(NBR,Hs90)	1
16	Gasket	40012493	—	1
31	O-ring	007912719	AS568-127(NBR,Hs90)	2
39	O-ring	007901119	AS568-011(NBR,Hs90)	2
41	O-ring	007901819	AS568-018(NBR,Hs90)	1

P40V

Item	Name	Part No.	Standard	Qty
4	O-ring	007913817	AS568-138(NBR,Hs70)	1
5	Shaft seal	VA29405	—	1
7	O-ring	007990619	AS568-906(NBR,Hs90)	1
9	O-ring	007991219	AS568-912(NBR,Hs90)	1
16	Gasket	40012857	—	1
31	O-ring	007914117	AS568-141(NBR,Hs70)	2
39	O-ring	007901119	AS568-011(NBR,Hs90)	2
41	O-ring	007901819	AS568-018(NBR,Hs90)	1

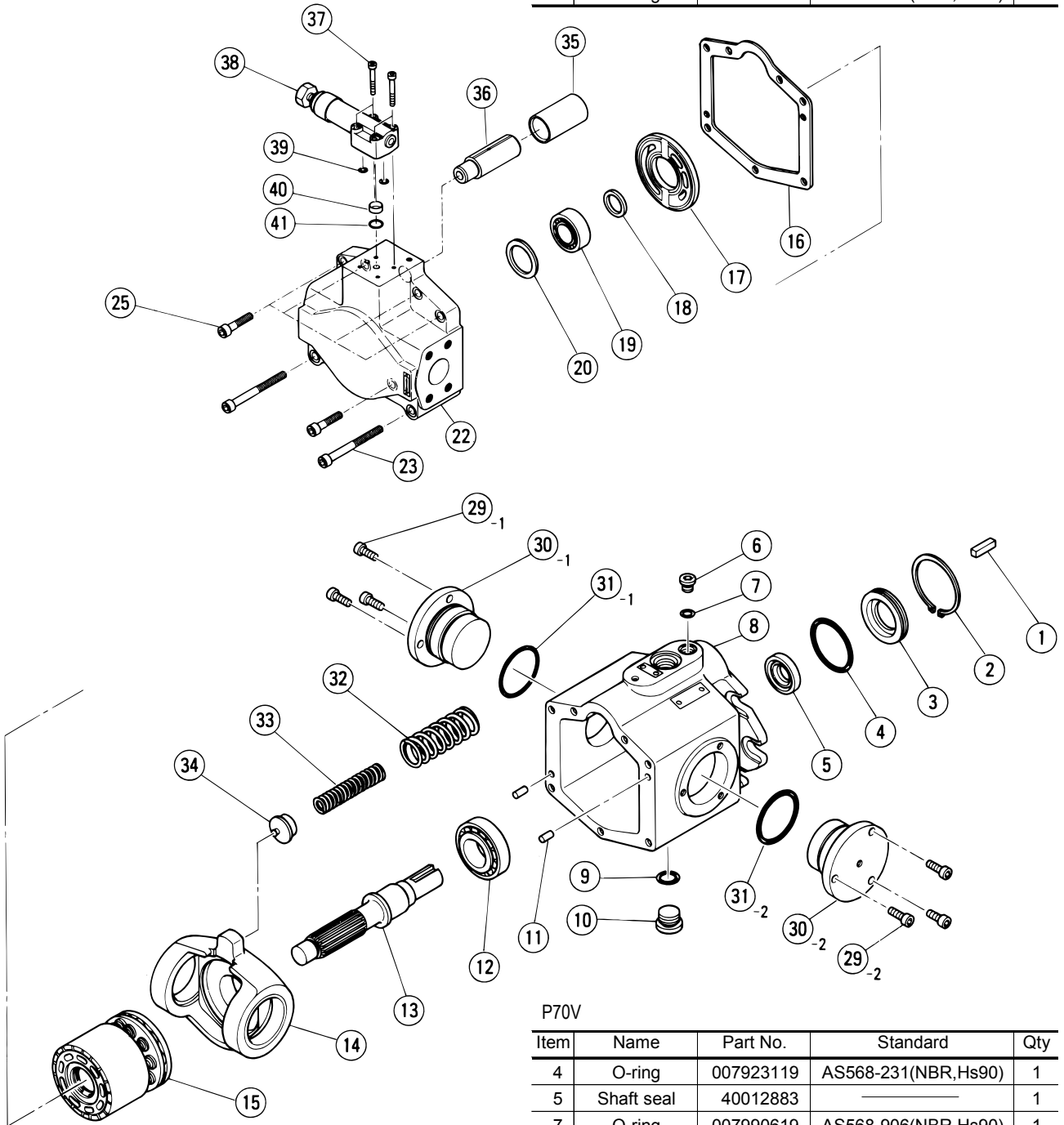

Rotating Group Kits

Model	P21V	P31V	P40V	P70V
Kit P/N	40058739	40058739	40058728	40048024
R rotation No.17 w/wafer plate	40058258		40058726	40048805
L rotation No.17 w/wafer plate	40058259		40058727	40048806

P70V

Item	Name	Part No.	Standard	Qty
4	O-ring	007923119	AS568-231(NBR,Hs90)	1
5	Shaft seal	40012883	—	1
7	O-ring	007990619	AS568-906(NBR,Hs90)	1
9	O-ring	007991219	AS568-912(NBR,Hs90)	1
16	Gasket	VA30439	—	1
31	O-ring	007914917	AS568-149(NBR,Hs70)	2
39	O-ring	007901119	AS568-011(NBR,Hs90)	2
41	O-ring	007901819	AS568-018(NBR,Hs90)	1

P100V

Item	Name	Part No.	Standard	Qty
4	O-ring	007933817	AS568-338(NBR,Hs70)	1
5	Shaft seal	40011048	—	1
7	O-ring	007991219	AS568-912(NBR,Hs90)	1
10	O-ring	007991219	AS568-912(NBR,Hs90)	1
18	Gasket	40011573	—	1
28	O-ring	007924119	AS568-241(NBR,Hs90)	2
35	O-ring	007991019	AS568-910(NBR,Hs90)	1
38	O-ring	007991019	AS568-910(NBR,Hs90)	1
41	O-ring	007901119	AS568-011(NBR,Hs90)	2
43	O-ring	007901819	AS568-018(NBR,Hs90)	1

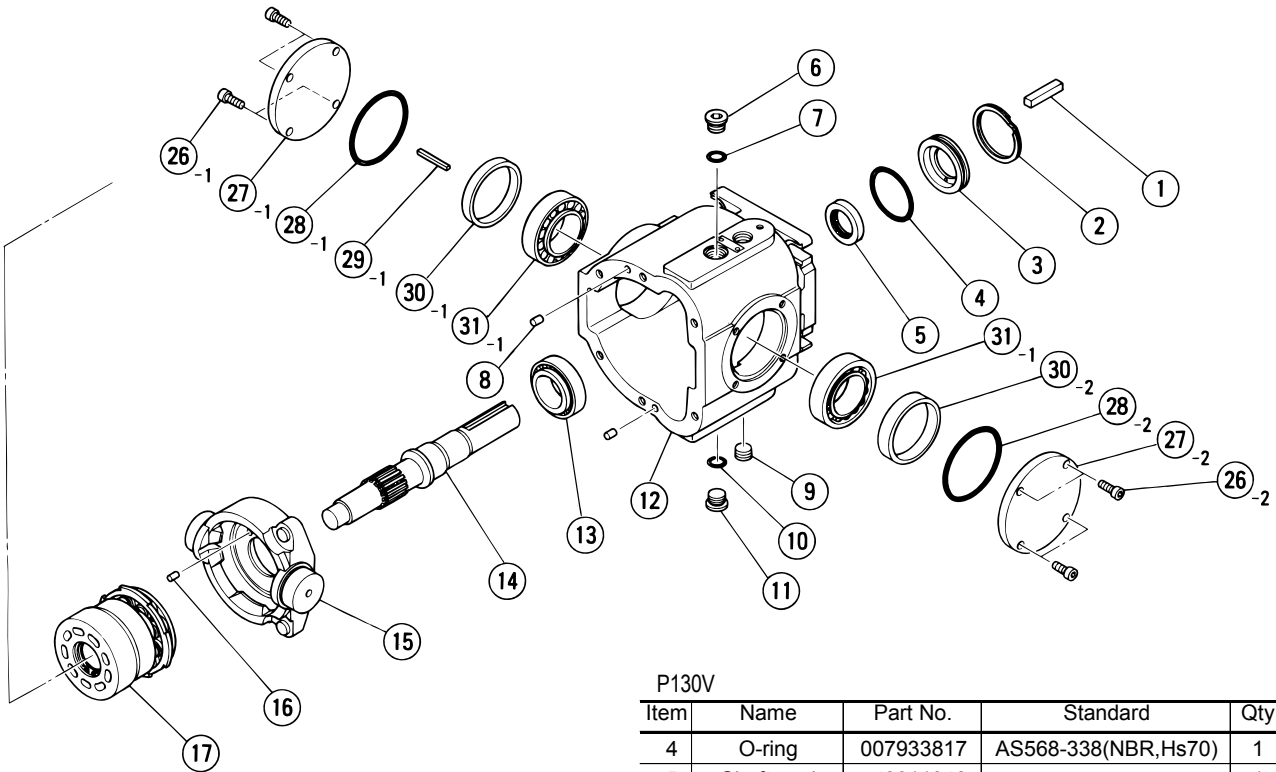
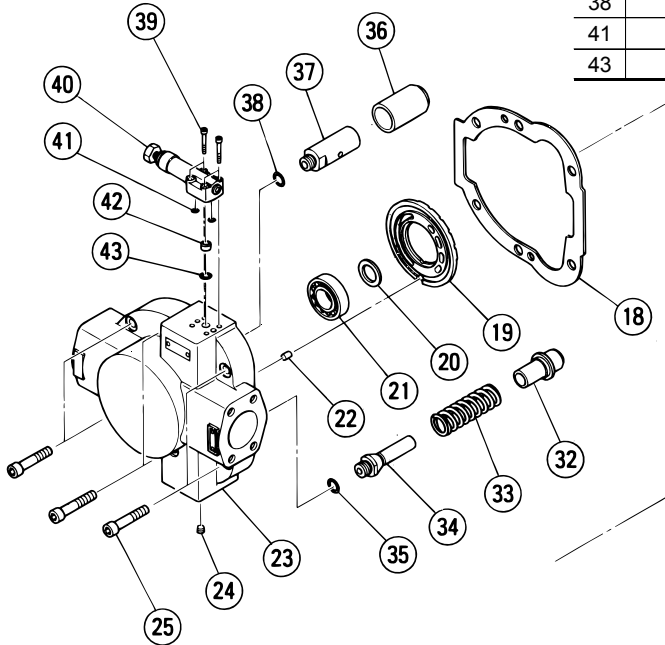

P130V

Item	Name	Part No.	Standard	Qty
4	O-ring	007933817	AS568-338(NBR,Hs70)	1
5	Shaft seal	40011048	—	1
7	O-ring	007991219	AS568-912(NBR,Hs90)	1
10	O-ring	007991219	AS568-912(NBR,Hs90)	1
18	Gasket	40011616	—	1
28	O-ring	007924719	AS568-247(NBR,Hs90)	2
35	O-ring	007991019	AS568-910(NBR,Hs90)	1
38	O-ring	007991019	AS568-910(NBR,Hs90)	1
41	O-ring	007901119	AS568-011(NBR,Hs90)	2
43	O-ring	007901819	AS568-018(NBR,Hs90)	1

Rotating Group Kits

Model	P100V	P130V
Kit P/N	40038744	40058363
R rotation No.19 w/wafer plate	40048836	40058361
L rotation No.19 w/wafer plate	40048837	40058362

Low Noise, High Pressure Variable Displacement Piston Pump PH Series

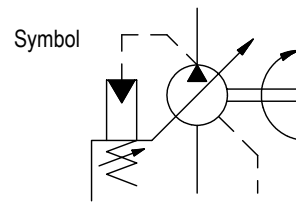
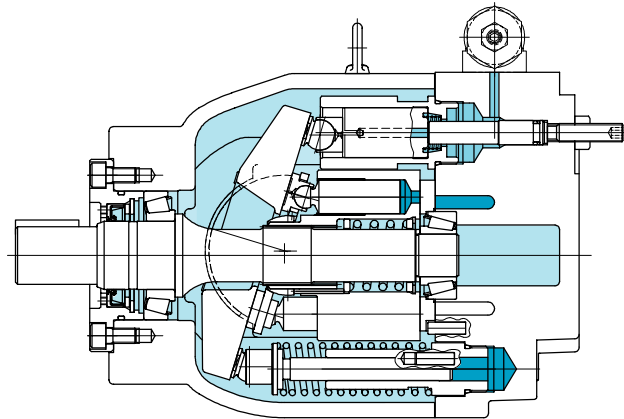
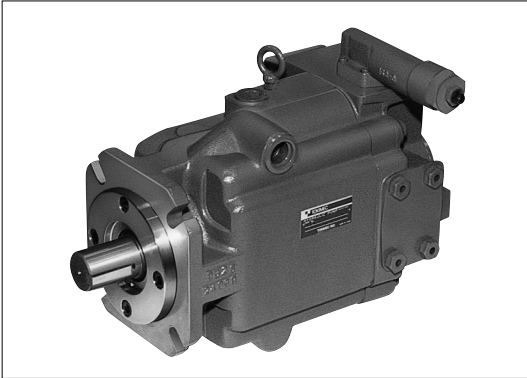

Model Code

PH100 - MS (*) (F) YR - 20 - CH - (D) - 10 - (S38)

1 2 3 4 5 6 7 8 9 10 11 12

- | | |
|--|--|
| <p>1 PH Series variable displacement piston pump
PH80,PH100,PH130,PH170</p> <p>2 Port specifications
M: standard</p> <p>3,4 Code for double pump
S: single pump
*Contact TOKIMEC for double pump configurations</p> <p>5 Pump mounting
Omitted: flange mounting
F: foot bracket</p> <p>6 Shaft end configuration
Y: long shaft w/SAE square key</p> <p>7 Rotation (viewed from shaft end)
R: right rotation (clockwise)
L: left rotation (counter-clockwise)</p> | <p>8 Pump design no.</p> <p>9 Pump control
CH : pressure compensator
CGH : remote pressure compensator
CVH : load sensing
TL : torque limiter (low)
TH : torque limiter (high)
EDHS : electric direct control (flow,pressure)</p> <p>10 Max. displacement adjuster
Omitted : none
D : w/ adjuster</p> <p>11 Control valve design no.</p> <p>12 Suffix
S38 : for TL/TH models
Omitted : other</p> |
|--|--|

Specifications

Model	Max. Displ. cm ³ /rev	Working Pressure MPa	Max. Speed min ⁻¹	Min. Speed min ⁻¹	Weight kg
PH80	80	Rated 28 Intermit. 30	1800	600	51
PH100	100				70
PH130	130				95
PH170	170	Rated 21 Intermit. 22.5			

- Intermittent pressure means pressure less than 10% of duty cycle (max. 6 seconds).
Contact Tokimec for applications which exceed rated working pressure.

- Rated pressure of electric direct control EDHS is 21 MPa.
This pressure is controlled by relief valve setting.
- Weight is for CH type (pressure compensator).
- Contact TOKIMEC when using water glycol

Pump Control Method		Characteristics Curve	Remarks	Symbol
Type	Code			
Pressure compensator	CH		<ul style="list-style-type: none"> When pump delivery pressure rises to the setting pressure, pump flow is automatically reduced to the minimum flow needed to maintain the pressure. Pressure can be set with manual adjustment. 	
Remote pressure compensator	CGH		<p>CGH</p> <ul style="list-style-type: none"> Pressure setting of compensator control can be set with a remote control valve. Pressure compensator type relief valve. Pressure setting can be adjusted manually. 	
Load sensing	CVH		<ul style="list-style-type: none"> Pump delivery automatically controlled to maintain constant differential pressure across flow control valve located downstream of pump. Energy-saving type pump control which supplies minimum flow and pressure necessary to drive load(actuator). Pressure compensator safety relief valve integrated. Setting pressure can be manually set. Remote pressure compensator control possible with externally installed remote control valve. 	
Torque limiter (low torque/high torque)	TL / TH		<ul style="list-style-type: none"> Pump delivery automatically controlled to match load capacity of the electric motor. Flow setting can be manually adjusted. Pressure compensator safety relief valve integrated. Setting pressure can be manually set. Remote pressure compensator control possible with externally installed remote control valve. 	
Electric direct control	EDHS		<ul style="list-style-type: none"> In flow control mode, pump delivery is controlled by flow control signal and as pump delivery pressure approaches the pressure setting signal, mode automatically switches to pressure control. Special controller EDA-PQ necessary. Pressure compensator safety relief valve integrated. Setting pressure can be manually set. 	
Maximum displacement adjustment function	D		<ul style="list-style-type: none"> Maximum displacement adjustment with adjustment screw on pump. 	<p>Displacement adjuster symbol</p>

Max displacement adjuster characteristics

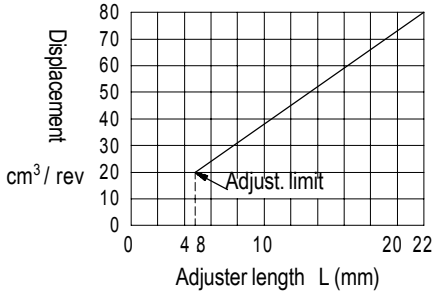

PH80 SERIES

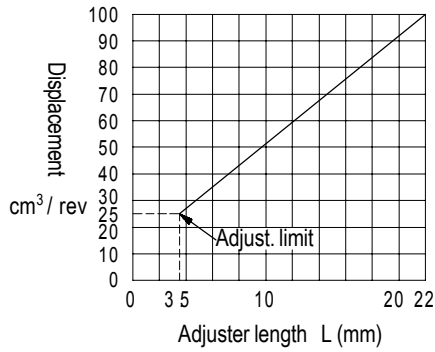

PH100 SERIES

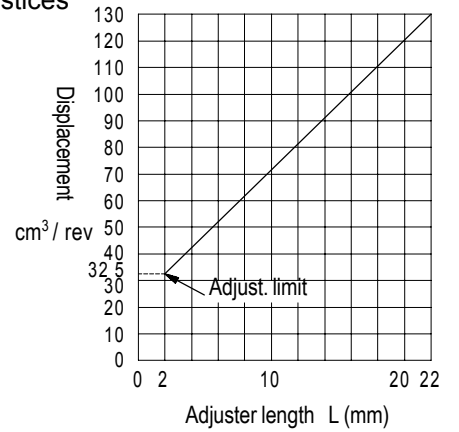

PH130 SERIES

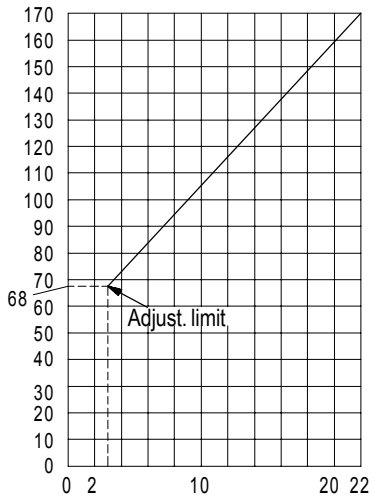

PH170 SERIES

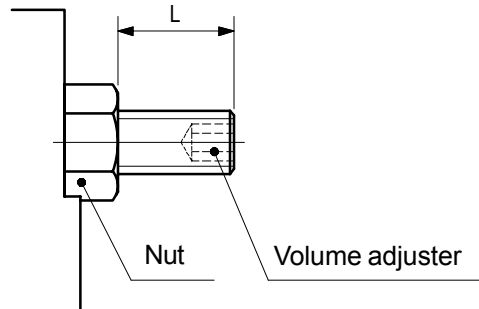

Characteristics Curve (at 20 mm²/s)

Pressure, efficiency, delivery, input power (1800min⁻¹)

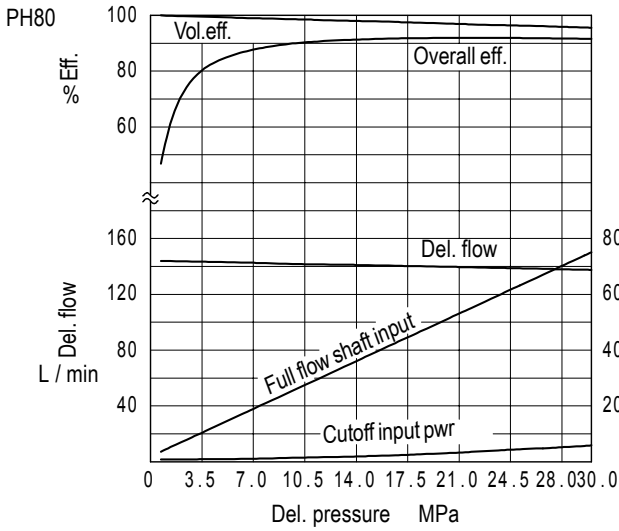

Pressure, noise characteristics (1 m from pump rear)

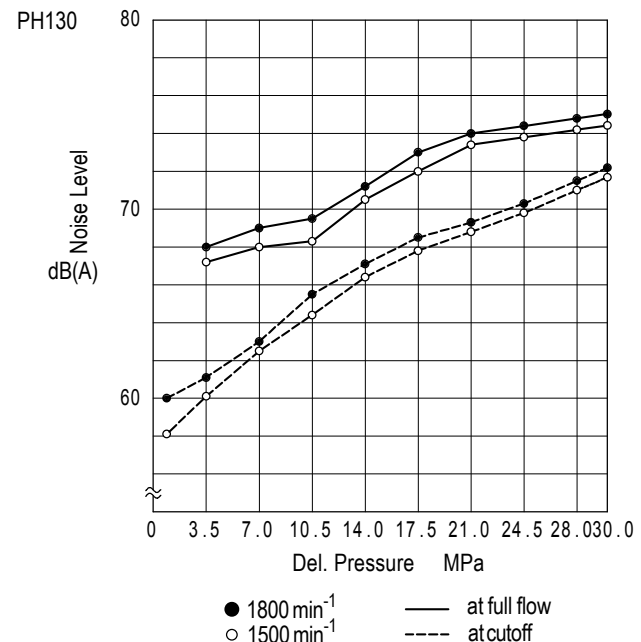
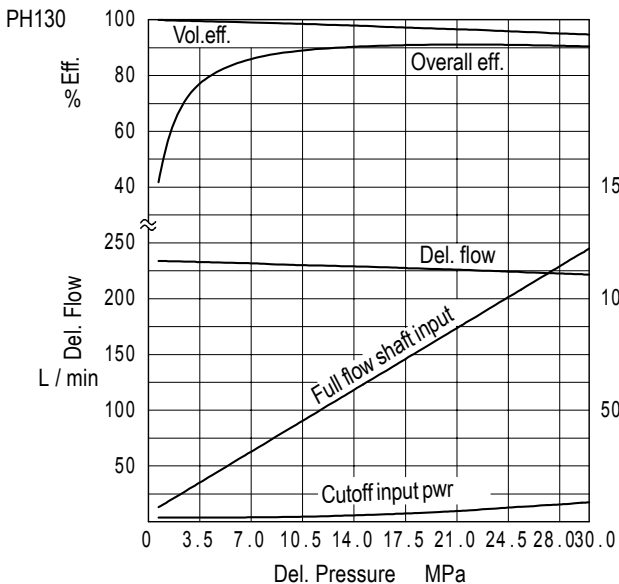
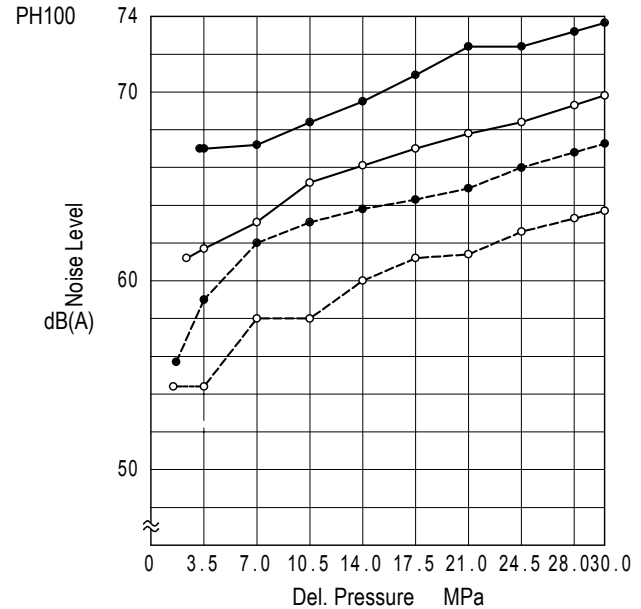
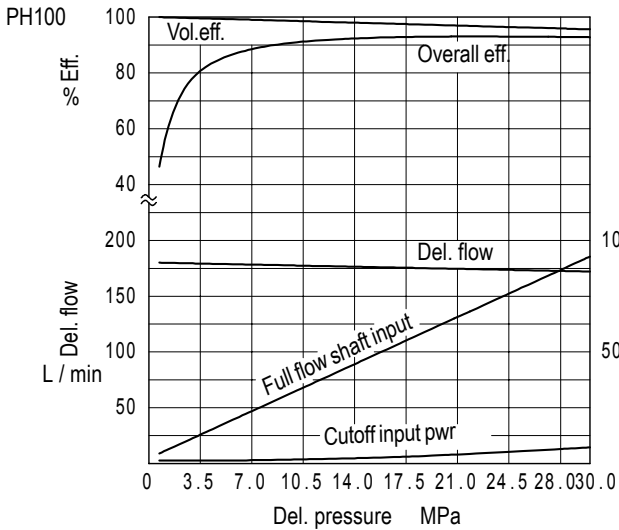
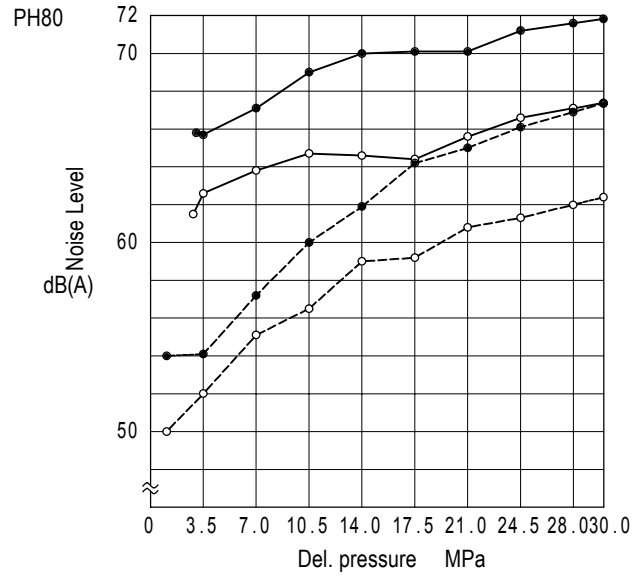

Characteristics Curve (at 20mm²/s)

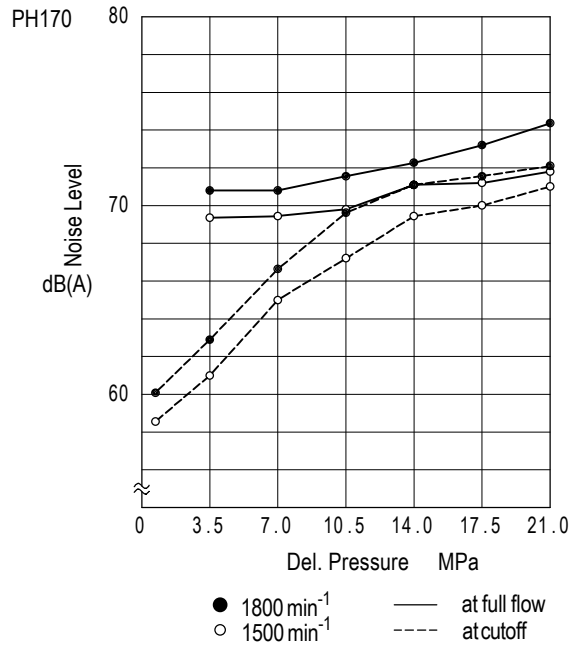
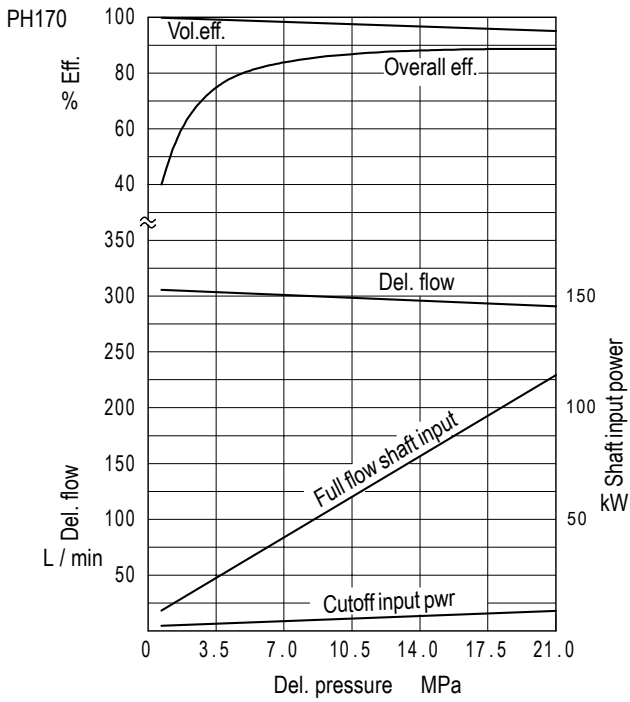

Pressure, drain flow characteristics (1800 min⁻¹, 20mm²/s)

AT FULL FLOW

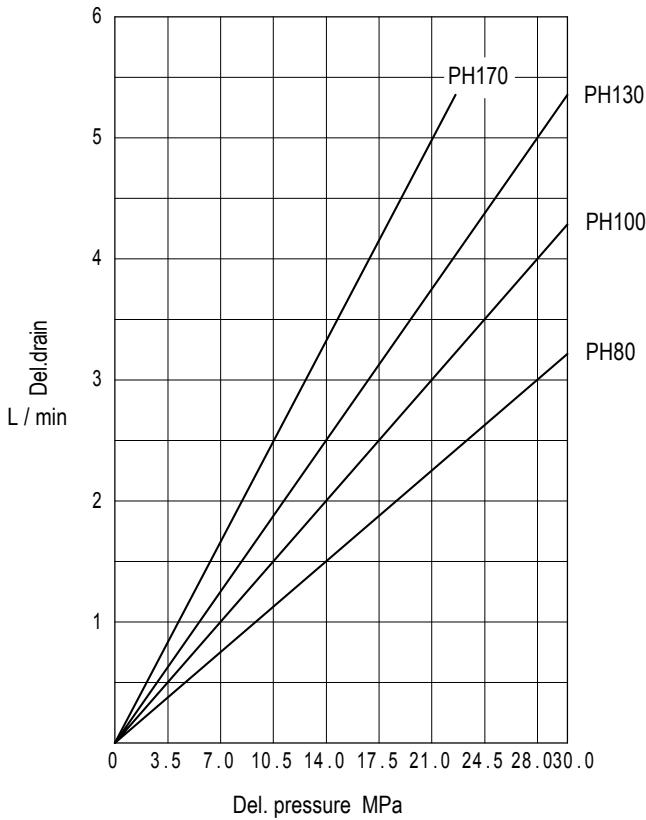

AT CUTOFF (CH:Pressure compensator)

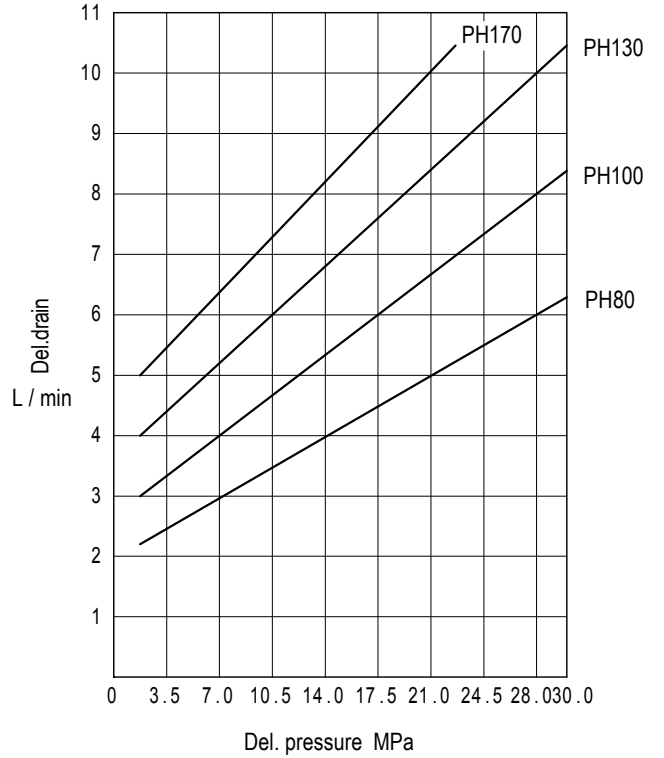

PH80

NOTE:
Right rotation model shown. For left rotation,
control valve shall move to symmetrical position
from center line.

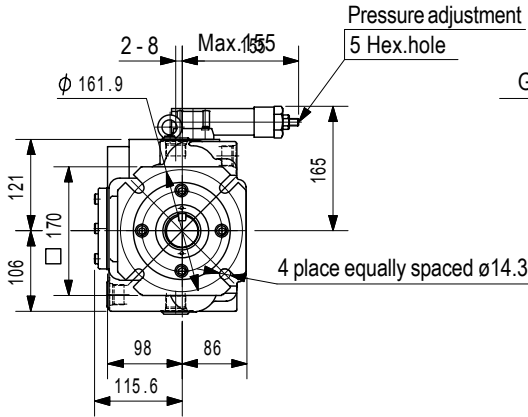

FOOT MOUNT

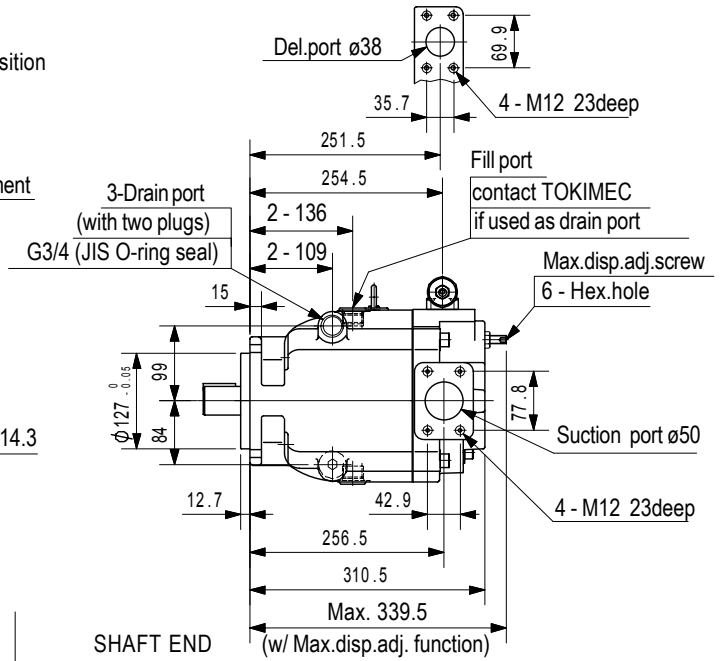
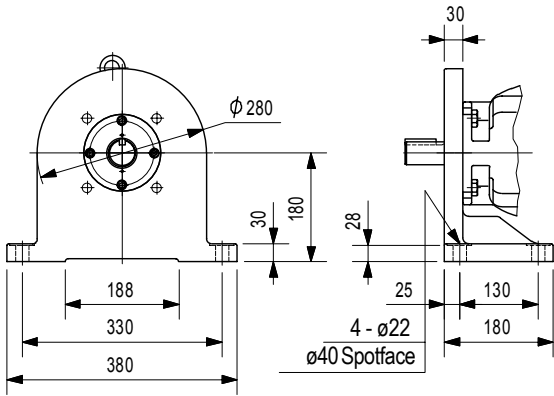

SHAFT END

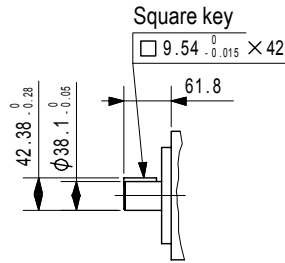

SHAFT END "X"

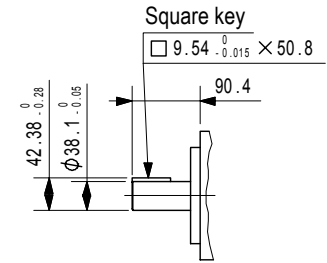

SHAFT END "Y"

PH100

NOTE:
Right rotation model shown. For left rotation,
control valve shall move to symmetrical position
from center line.

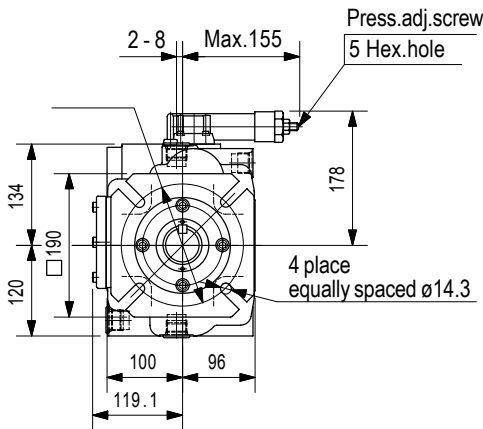

FOOT MOUNT

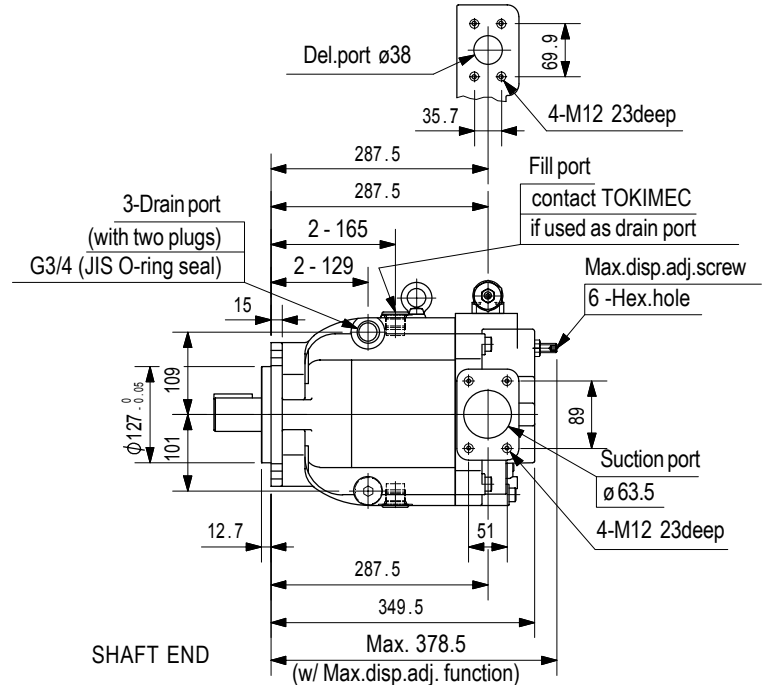
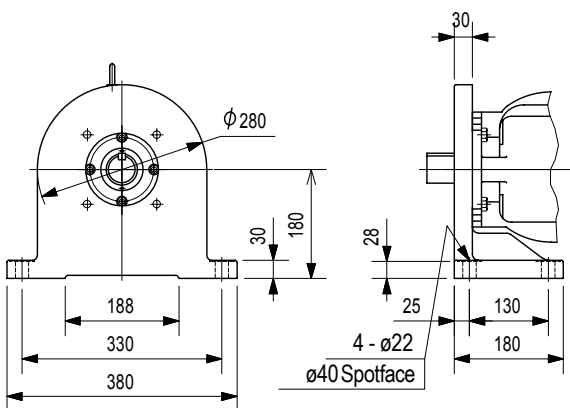

SHAFT END

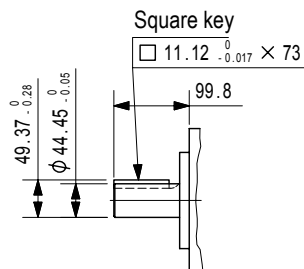

PH130
PH170

NOTE:
Right rotation model shown. For left rotation,
control valve shall move to symmetrical position
from center line.

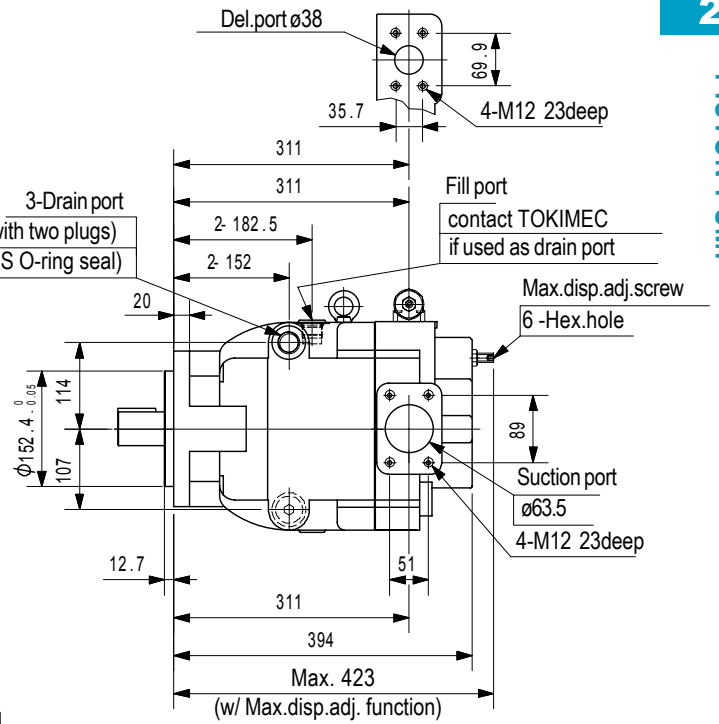
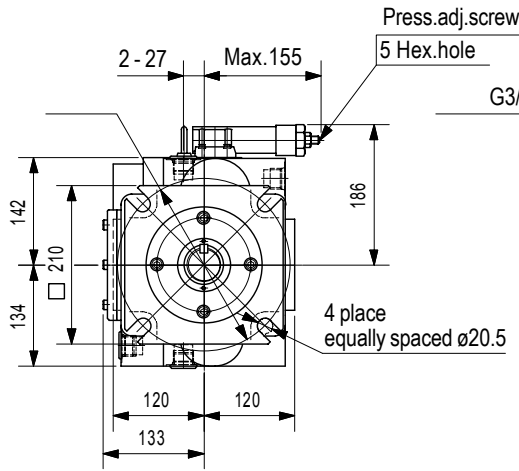

FOOT MOUNT

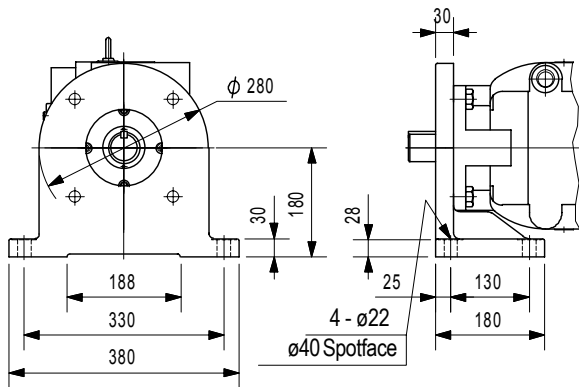

SHAFT END

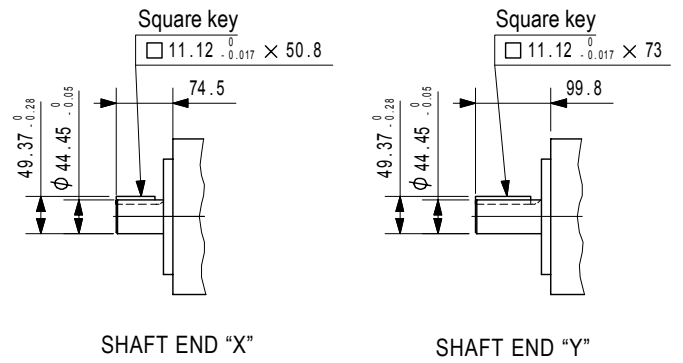

Notes on Operation

- See piston pump Notes on Operation (page A4, A5)

Construction

PUMP

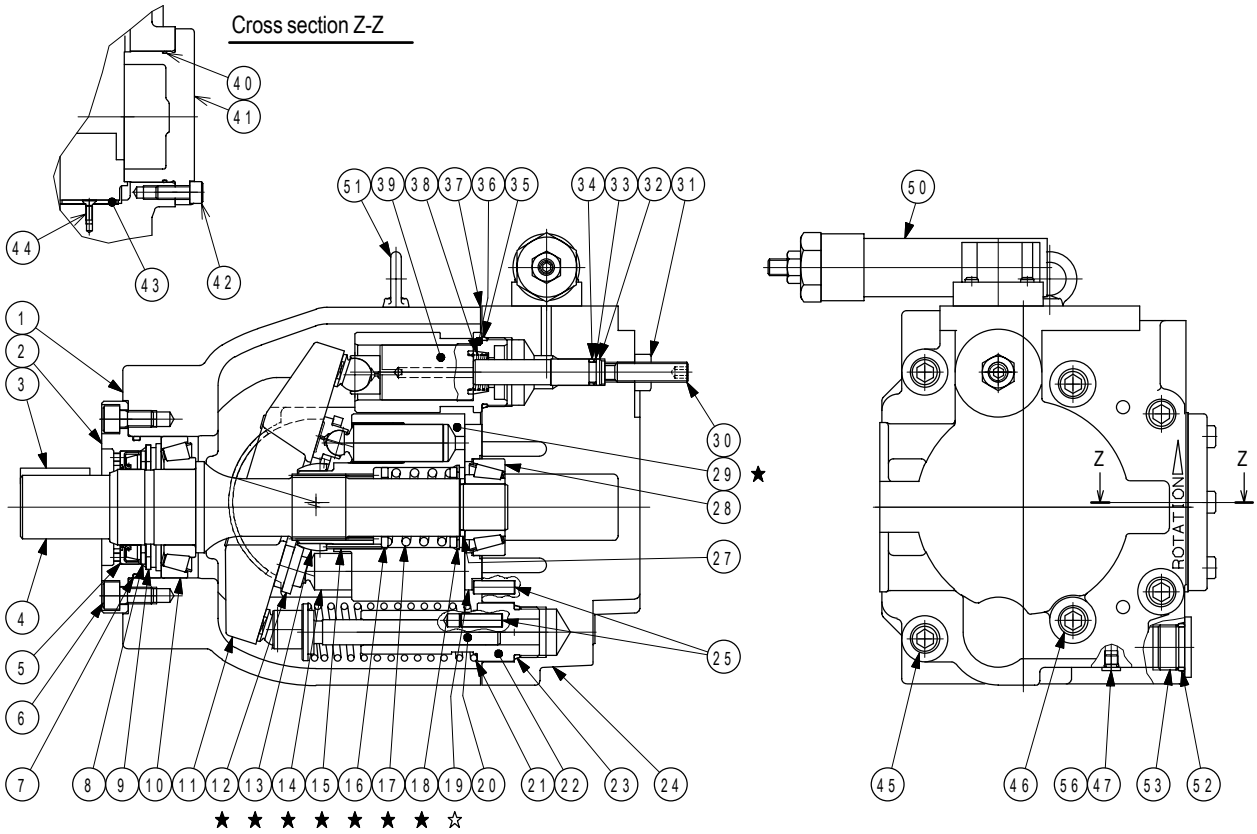

PH80

Item	Name	Part No.	Standard	Qty
5	Shaft seal	VA19648	—	1
7	O-ring	008051219	JIS B 2401 1B-G80	1
23	O-ring	007991419	AS568-914(NBR,Hs90)	1
33	Backup ring	008101202	JIS B 2407 T2-P12	1
34	O-ring	008001219	JIS B 2401 1B-P12	1
35	O-ring	007992019	AS568-920(NBR,Hs90)	1
37	Gasket	40017811	—	1
40	O-ring	007904119	AS568-041(NBR,Hs90)	1
52	O-ring	008002219	JIS B 2401 1B-P22.4	3
56	O-ring	007990219	AS568-902(NBR,Hs90)	4

PH100

Item	Name	Parts No.	Standard	Qty
5	Shaft seal	40011048	—	1
7	O-ring	008051319	JIS B 2401 1B-G85	1
23	O-ring	007991419	AS568-914(NBR,Hs90)	1
33	Backup ring	008101202	JIS B 2407 T2-P12	1
34	O-ring	008001219	JIS B 2401 1B-P12	1
35	O-ring	007992019	AS568-920(NBR,Hs90)	1
37	Gasket	40021003	—	1
40	O-ring	007904319	AS568-043(NBR,Hs90)	1
52	O-ring	008002219	JIS B 2401 1B-P22.4	3
56	O-ring	007990219	AS568-902(NBR,Hs90)	4

PH130/PH170

Item	Name	Parts No.	Standard	Qty
5	Shaft seal	40011048	—	1
7	O-ring	008051419	JIS B 2401 1B-G90	1
23	O-ring	007991419	AS568-914(NBR,Hs90)	1
33	Backup ring	008101202	JIS B 2407 T2-P12	1
34	O-ring	008001219	JIS B 2401 1B-P12	1
35	O-ring	007992019	AS568-920(NBR,Hs90)	1
37	Gasket	40024503	—	1
40	O-ring	007904519	AS568-045(NBR,Hs90)	1
52	O-ring	008002219	JIS B 2401 1B-P22.4	3
56	O-ring	007990219	AS568-902(NBR,Hs90)	4

Rotating Group Kit

Model	PH80	PH100	PH130	PH170
Rotating group kit (★marked parts)	40048885	40038843	40058177	40068811
Right hand rotating group kit(★, ☆marked parts)	40068523	40068507	40068562	40068854
Left hand rotating group kit(★, ☆marked parts)	40068524	40068508	40068563	40068855

Seal kit for pump (not including control valves)

Model	PH80	PH100	PH130/PH170
Seal kit part no.	40068287	40068288	40068289

Construction

Pressure Compensator (CH: pressure compensator)

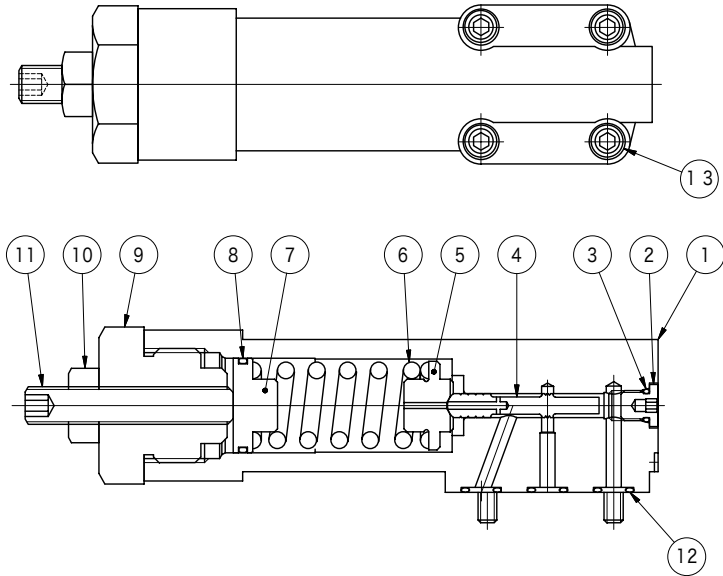

Item	Name	Parts No.	Standard	Qty
3	O ring	007990219	AS568-902(NBR,Hs90)	1
8	O ring	007902019	AS568-020(NBR,Hs90)	1
12	O ring	007901119	AS568-011(NBR,Hs90)	3